

Transference of relationship qualities
to a virtual world:
Regulation of behavior to a virtual spouse

D I S S E R T A T I O N

zur Erlangung des akademischen Grades

doctor rerum naturalium (Dr. rer. nat.) im Fach Psychologie

eingereicht an der

Mathematisch-Naturwissenschaftlichen Fakultät II der Humboldt-Universität zu Berlin

von Diplom-Psychologe Felix Schönbrodt, geboren am 13.07.1980 in Starnberg

Präsident der Humboldt-Universität zu Berlin: Prof. Dr. Dr. h.c. Christoph Markschies

Dekan der Mathematisch-Naturwissenschaftlichen Fakultät II: Prof. Dr. Peter Frensch

Gutachter: Prof. Dr. Jens B. Asendorpf, Humboldt-Universität zu Berlin

Prof. Dr. Rainer Banse, Universität Bonn

Prof. Dr. Manfred Schmitt, Universität Koblenz-Landau

Tag der Verteidigung: 29. Oktober 2010

Für meine Familie

Table of Contents

Danksagung.....	III
Abstract.....	IV
Zusammenfassung.....	V
Chapter 1: Introduction.....	1
Chapter 2: The challenge of constructing psychologically believable agents.....	17
Chapter 3: Virtual social environments as a tool for psychological assessment: Dynamics of interaction with a virtual spouse.....	36
Chapter 4: Transference of adult attachment dynamics to a virtual spouse.....	63
Curriculum Vitæ.....	97
Schriftenverzeichnis.....	99

Danksagung

Zuerst möchte ich meinem Doktorvater Prof. Dr. Jens B. Asendorpf danken. Er hat mir bei der Bearbeitung dieser Fragestellung große Freiheiten gelassen, an entscheidenden Stellen jedoch das Projekt immer wieder in die richtigen Bahnen gelenkt. Die große räumliche Distanz war kein Hindernis für eine enge und detaillierte Betreuung, und die workshopartigen Treffen in Berlin werden mir immer in reger Erinnerung bleiben.

Mein Dank gebührt auch Wiebke Neberich, Birk Hagemeyer und Franz Neyer, mit denen bei den Projekttreffen viel diskutiert wurde. Insbesondere Birk danke ich für die unzähligen inspirierenden Gespräche - viele meiner Erkenntnisse sind daraus entsprungen.

Großer Dank gebührt auch der Studienstiftung des deutschen Volkes, durch deren Promotionsstipendium diese Dissertation möglich wurde.

Mein ganz besonderer Dank gilt jedoch meiner Familie, der diese Arbeit gewidmet ist: meinen Eltern, die mich auf meinem ganzen Weg immer unterstützt haben, und von denen ich immer wusste, dass sie hinter mir stehen. Ich danke meinem Sohn Leonhard, dass er mich immer wieder daran erinnert hat, dass es eine wunderbare Welt jenseits des Arbeitsplatzes gibt. Einer Person gilt jedoch mein besonderer Dank. Sie hat mich immer wieder bestärkt, beruhigt, motiviert, und im richtigen Moment auch abgelenkt: meine Frau Verena.

Abstract

This dissertation investigates to which extent internal working models of relationships and personality characteristics of participants are transferred to computer-generated agents in a virtual social environment (VSE). For this purpose a VSE was created that was populated with several autonomous agents which interacted with each other. Participants can control one of the the agents (the "protagonist"); one of the other agents is the spouse of the protagonist. Using this setup, a potential projection screen for the dynamics of the real-life relationship, as well as for generalized internal working models was created.

Chapter 1 summarizes the research question, gives an overview of the development of the VSE called "Simoland", and provides a general summary and conclusion about the dissertation.

Chapters 2 - 4 each are self-contained manuscripts. Chapter 2 („The challenge of constructing psychologically believable agents“) is a theoretical article which describes challenges and new possibilities in the implementation of psychological models into autonomous agents.

Chapter 3 („Virtual social environments as a tool for psychological assessment: Dynamics of interaction with a virtual spouse“) describes the first empirical study conducted in Simoland. This study demonstrates how intrapersonal changes in interaction behavior can be investigated in VSEs. With a sample of 236 participants I could show that both the relationship satisfaction with the real life partner, and the intimacy motive of the participant had an influence on the behavior towards the virtual spouse. Hence, it could be shown that virtual behavior indeed is connected to conditions of the real world.

While the first study investigated unrestricted behavior in an open world, in Chapter 4 („Transference of adult attachment dynamics to a virtual spouse“) specific, theoretically derived scenes were created which were supposed to activate the attachment system. With a sample of 422 participants we could demonstrate interindividual differences in attachment behavior as a reaction to one of three scenes: a separation, a conflict with the virtual spouse, and a threatening situation. Both attachment anxiety and attachment avoidance significantly and meaningfully correlated with the behavior in the VSE, the physical distance between protagonist and virtual spouse, and emotional ratings.

To summarize, this dissertation for the first time shows that qualities of real-life relationships, as well as internal working models of attachment, are transferred to virtual agents. Thereby new ways are opened to investigate behavior in close relationships and representations of significant others through virtual scenarios.

Zusammenfassung

Diese Dissertation untersucht, inwieweit Beziehungsrepräsentationen und Persönlichkeitsmerkmale von Personen auf computergenerierte Agenten in einer virtuellen sozialen Umgebung (VSU) übertragen werden. Dazu wurde eine VSU erstellt, in der Teilnehmer eine virtuelle Figur (den „Protagonisten“) steuern können, welche wiederum mit anderen autonomen Agenten interagiert. Einer dieser anderen Agenten ist der virtuelle Partner/ die virtuelle Partnerin des Protagonisten, womit eine mögliche Projektionsfläche für die Beziehungsdynamik der realen Partnerschaft sowie für generalisierte interne Arbeitsmodelle von Beziehungen hergestellt wurde.

Kapitel 1 fasst die Forschungsfrage zusammen und beschreibt den Entstehungsprozess der VSU namens „Simoland“, und gibt eine kurze Zusammenfassung der Gesamtergebnisse.

Kapitel 2 – 4 stellen jeweils eigenständige Manuskripte dar. Kapitel 2 („The challenge of constructing psychologically believable agents“) ist ein theoretischer Artikel, der Herausforderungen und neue Wege beschreibt wie psychologische Modelle in autonome Agent implementiert werden können.

Kapitel 3 („Virtual social environments as a tool for psychological assessment: Dynamics of interaction with a virtual spouse“) beschreibt die erste psychologische Untersuchung in Simoland, welche demonstriert wie intraindividuelle Entwicklung im Interaktionsverhalten untersucht werden kann. An einer Stichprobe von 236 Teilnehmern konnte gezeigt werden, dass sowohl die Beziehungszufriedenheit zum realen Partner, als auch das Intimitätsmotiv der Teilnehmer einen Einfluss auf das Verhalten in der VSU hatten, und somit das virtuelle Verhalten tatsächlich verknüpft ist mit der realen Welt.

Während die erste Studie freies Verhalten untersucht hat, wurden in der zweiten Studie theoriegeleitet verschiedene Szenarien hergestellt, welche das Bindungssystem aktivieren sollen (Kapitel 4: „Transference of adult attachment dynamics to a virtual spouse“). Dadurch konnten an 422 Teilnehmern interindividuelle Unterschiede im Bindungsverhalten als Reaktion auf folgende Szenen gezeigt werden: eine Trennungssituation, eine Konfliktsituation, sowie eine Bedrohungssituation. Die dimensionalen Bindungsstile (Bindungsvermeidung und Bindungsängstlichkeit) korrelierten sinnvoll und signifikant mit dem Verhalten in der VSU, der physikalischen Distanz zwischen Protagonist und Partner/in, sowie Emotionseinschätzungen.

Zusammenfasst zeigt diese Dissertation zum ersten Mal, dass Qualitäten der realen Partnerschaft, sowie interne Arbeitsmodelle der Bindung auf virtuelle Agenten übertragen werden. Somit werden neue Wege eröffnet, Beziehungsverhalten und -repräsentationen in virtuellen Szenarien zu untersuchen.

Chapter 1

Introduction

Investigating close relationships

Having a close relationship is amongst the highest rated goals in our society (Deutsche Shell Holding, 2006), and intimate relationships have numerous benefits for health and well-being (Prager, 1995). For these and many other reasons, the investigation of close relationships is a fruitful and exciting field in psychological science. However, research in this area has some specific challenges. The American Psychological Association's "Decade of Behavior" comes to an end, and several scholars emphasized the importance of behavioral observations, in contrast to relying exclusively on self-report measures (Baumeister, Vohs, & Funder, 2007; Furr, 2009). Especially in the field of relationships and social interactions, researchers have a strong distrust in self-report measures and argue that the observation of interactional processes is the key for understanding relationship outcomes (Gottman, 1998). As behavioral observations are costly, labor-intensive, and frustrating, many researchers are reluctant to undertake this effort (Gottman, 1998). Beyond that, it is hard or impossible to create certain situations with real couples. For example, most studies on jealousy have been conducted with written vignettes or questionnaires. These vignettes, however, lack the social significance and social consequences of real situations, and the validity of self-reported hypothetical reactions to these hypothetical situations can be questioned (Furr, 2009). Especially with such an emotionally laden topic, observations of actual behavior would be particularly informative. However, it is hard to create a situation of serious jealousy with real couples in the laboratory - neither romantic partners, nor ethic committees will approve such an approach. In this and other situations, virtual environments might be useful tools for the generation and observation of behavior.

A New Approach For the Study of Close Relationships: Virtual Social Environments

Virtual environments (VEs) are advocated as a powerful tool to bridge the gap between increased realism and dynamics of social interactions, and the increased controllability of laboratory experiments (Asendorpf, 2004; Blascovich et al., 2002). VEs have the potential to overcome many of the restrictions expressed above, as they are supposed to have several advantages in contrast to conventional methods like self-report measures, laboratory studies, or interviews. First, both data collection and data analyses can be more easily accomplished: Testing can be done over the internet, and due to automatic

coding, reliable behavioral indices can be obtained without the effort of coding hours of video material. Second, the researcher has full control over the actions and reactions of the virtual interaction partners, which opens up new possibilities of experimentally varying the partner's behavior. Tying in with the jealousy example from above, special scenarios can be created that are hard or impossible to create in the laboratory with real persons. Third, in contrast to situations described in vignettes, interpersonal situations in VSEs are anchored in the experiential system (McClelland, Koestner, & Weinberger, 1989; Schultheiss, 2001). For example, situation-contingent facial expressions of the agents, background music, or triggered events can be used to increase the feeling of immersion of the participant and to elicit spontaneous and automatic reactions. And in contrast to hypothetical self-reported reactions, in VSEs spontaneous behaviors as well as the dynamics of behavior over time can be investigated (see Chapter 3).

These features of VEs look very promising. Concerning the social interactivity with other inhabitants of these environments, however, the majority of existing research in VEs so far only has covered relatively simple scenarios. Examples are the measurement of interpersonal physical distance towards a static agent that does not interact at all (Bailenson, Blascovich, Beall, & Loomis, 2003; Dotsch & Wigboldus, 2008), or giving a talk in front of some agents, which either show friendly or hostile reactions, regardless of participants' actual performance. Only one study is known to the authors, which investigated close relationships in virtual worlds. Frey, Blunk, and Banse (2006) sent couples into the same virtual world (each partner sat in another room at a PC and their avatars met in the virtual world). In this study, actually human-human interaction of a couple was studied, mediated through the VE.

To my knowledge, no study so far has been conducted where ongoing human behavior towards an interactive agent is embedded in a rich social context. Hence, for the purpose of this dissertation, the following framework is proposed: A *virtual social environment*¹ (VSE) is a virtual environment that is populated with autonomous agents. These agents show a sufficiently believable behavior, such that relatively natural interactions can take place. In the implementation used in this dissertation, participants can control one of these agents (called *the protagonist*) that has a virtual romantic relationship to another agent in the VSE (the *virtual spouse*). Participants can instruct the protagonist to perform more than 30 different

1. The label "virtual social environment" is used as a superordinate concept which includes the full range between photorealistic immersive virtual environments and simple two-dimensional computer games with virtual characters. All of them form a sort of environment where users can interact with other characters.

actions with the spouse (for details, see Chapter 3), and the spouse reacts to them according to an underlying psychological model (for details, see Chapter 2). Several indices derived from gaming behavior serve as dependent variables: behavioral indices (i.e., which actions were chosen to be performed?), the physical distance between the protagonist and other agents in the VE, as well as short experience sampling questionnaires displayed during the game.

Skeptics may state that behavior in such VEs is completely arbitrary and has nothing to do with "real life". In the remainder of this dissertation it will be theoretically argued and empirically shown that, quite contrary to that apprehension, under appropriate conditions virtual behavior indeed reflects qualities of real life. Nonetheless, if close relationships are investigated in VSEs, a key assumption is that characteristics of the real life relationship or generalized internal working models of close relationships are transferred to the virtual world.

Transference

Transference towards humans is a concept with a long-standing tradition in psychotherapy. It describes the phenomenon that characteristics of past relationships to significant others are transferred to unknown people. While in the psychoanalytic tradition transference describes a pathological process, the concept has been re-conceptualized in social-cognitive terms and has been described as a normal phenomenon that happens every day (Saribay & Andersen, 2007). Transference is a well documented phenomenon. For example, Andersen and colleagues found that features of unknown target persons are inferred from features of a significant other, and that evaluations of the target are influenced by transference, both in explicit evaluations and in facial expressions (Andersen & Thorpe, 2009). Transference effects also influence expectancies for acceptance or rejection in a new relationship, triggers specific interpersonal behavior of the participants (Berk & Andersen, 2000), and activates specific motivations and goals (Berk & Andersen, 2008).

Comparably, attachment theory emphasizes the idea of transferring internal working models acquired in past relationships, especially in early childhood, to new relationships (Ainsworth, Blehar, Waters, & Wall, 1978; Bowlby, 1980; Fraley, 2007). While there is some debate about the specificity of these working models (Baldwin & Fehr, 1995; Fraley, 2007; La Guardia, Ryan, Couchman, & Deci, 2000; Pierce & Lydon, 2001; Sibley & Overall, 2008), empirical results generally support the effect of transference (e.g., Brumbaugh & Fraley, 2006, 2007; Mallinckrodt & Chen, 2004).

In this dissertation I propose two extensions to the framework of transference. First, just like towards other humans, transference can also take place towards a virtual agent. If the aim is to investigate internal working models of a person through transference, these agents might even be preferable as targets of transference, as they present a blank slate which is not distorted by unique characteristics of a real target person. Second, not only characteristics of past relationships are transferred to the virtual spouse, but also own emotions and behavioral tendencies are transferred to the protagonist, who performs these behaviors as a proxy person of the participant.

If behavior assessed in virtual environments should be of diagnostic value for real life behavior, it has to be shown that indeed behavioral programs, reaction norms, internal working models, motives, and other psychological constructs are transferred to relationships and interactions of the virtual world. Two manuscripts of this dissertation (Chapter 3 and 4) are the first studies that demonstrate that transference in fact happens in VSEs.

The Construction of a Virtual World

Requirements for a VSE

Due to the high effort of testing participants in the laboratory, studies in immersive virtual environments typically have sample sizes between 10 and 30 for each experimental condition, or even overall (e.g., Bailenson et al., 2003; Dotsch & Wigboldus, 2008; Klinger et al., 2005; Slater et al., 2006; Tichon & Banks, 2006). For the study of interindividual differences, however, sample sizes of 100 and more participants are desirable to have sufficient statistical power. To achieve such sample sizes, the first requirement for Simoland was that the studies could be run over the internet. Technical hurdles should be kept as low as possible, thus a secondary goal was that the game should run in any browser without the requirement to install additional plug-ins or software, which would repel many participants. Second, as I sought for a broad sample including older participants, the controls and handling of the game should be as easy as possible. Finally, I also ruled out the use of collaborators who control the other agents, as this would make studies both more expensive, and less controllable. Instead of that, I wanted to work with autonomous agents with whom the protagonist interacts.

The Implementation of Simoland

Most studies in virtual environments drew upon existing technical frameworks, for example sophisticated VEs with head-mounted displays (e.g., McCall, Blascovich, Young, & Persky, 2009), or existing computer games like Quake III (Frey et al., 2006; Frey, Hartig, Ketzler, Zinkernagel, & Moosbrugger, 2007). While both hardware and software of the first solution are very expensive (in sum 30'000 € - 50'000 €), the second solution can be used for free on standard PCs. Both solutions, however, do not meet my requirements stated above. Hence, both for economical reasons and for design considerations, I decided to implement my own VSE - an online computer game called "Simoland" which was populated with autonomous agents called "Simos". After several pre-test studies and having written more than 28'000 lines of code, Simoland was stable and ready to run (for a screen shot, see Figure 1 in Chapter 3).

Simoland was implemented as a two-dimensional game using the Adobe Flash technology (version 9). With that approach the game runs in any internet browser, the only requirement being an installed Flash Player plug-in (which applies to over 98% of internet users in Europe and the US, Adobe Systems Inc., 2009). The file size of the final program was 2.7 Mb, which means a loading time of some seconds with a regular broadband connection. After several pre-tests, a graphical user interface was developed that was sufficiently easy to handle. In a pilot study with 241 participants, over 84% agreed or strongly agreed that the handling of the game was easy, 12% were undecided, and only 4% disagreed. These percentages were comparable in the subsample of older participants (>40 years).

Autonomous Agents: The Behavior of the Simos

All agents in Simoland are autonomous agents. That means, they have several needs and they have a representation of the virtual world along with the behavioral programs to satisfy these needs. The Simos have five motivational systems: hunger, thirst, sleep, affiliation, and security. The first three of these are basic needs that have to be satisfied on a regular basis. The need for affiliation is implemented as the need to do leisure activities with moderately familiar others, and the need for security is implemented as the need to have contact with highly familiar others. Beyond these motivational systems, the agents' behavior generally followed a tit-for-tat rule, that is, they reciprocated the positivity of each interaction that was initiated.

All motivational systems are implemented as feedback control systems which continuously compare an actual value with an internal set point (Bischof, 1993). Any

deviation from this set point leads to an activation to reduce this discrepancy. In the implementation of the psychological model of motivation, several challenges had to be overcome, like the problem of action selection (i.e., if multiple, incompatible motivations are present, which gains control over the behavioral system?), or a sensible balancing of the parameters of these control systems. Details on these issues can be found in Chapter 2.

The protagonist is autonomous as well, although its behavioral program is restricted compared to that of the other agents. That means, when the participant does not give any commands to the protagonist for some time, it will show basic behaviors like searching for food and water, taking a nap, or listening to a MP3 player. In contrast to the other agents, however, the protagonist does not initiate social interactions (although it responds to interactions initiated by other agents). The security system of the virtual spouse is adjusted such that it seeks the closeness of the protagonist every 2-3 minutes. In the case of the security appetite, the mere closeness to a familiar other usually is sufficient to reduce the activation (Bischof, 2001). In cases of a very high activation of the security system, however, the spouse initiates an interaction to the protagonist (e.g., wants to talk about what happened today, or wants to kiss the protagonist).

The Virtual Spouse: An Avatar of the Real Life Partner?

One major decision had to be taken on how to visually design the virtual spouse. Generally, two approaches can be taken, each with its own appeal. On the one hand, one could try to model the real life partner as realistic as possible. This promises to instigate partner-specific scripts and reaction tendencies that reflect the current relationship. On the other hand, one could aim for a decrease of ego-involvement, explicit attitudes, and self-enhancement, to enable a measurement of rather implicit working models. In this case, one would take advantage of the mechanism of transference where internal working models automatically are applied onto unknown persons.

In a first attempt, I pursued the first alternative and tried to maximize the resemblance of the virtual spouse to the real life partner. For this purpose, a facial avatar editor was created with which participants could model an avatar (i.e., representation) of their real life partner. The avatar had the same first name as the real life partner and participants could adjust the hair color, hair-do, the shape, position, and color of mouth, nose, ears, eyes, etc. (see Figure 1). This avatar then was used as the virtual spouse in a second step of the study.

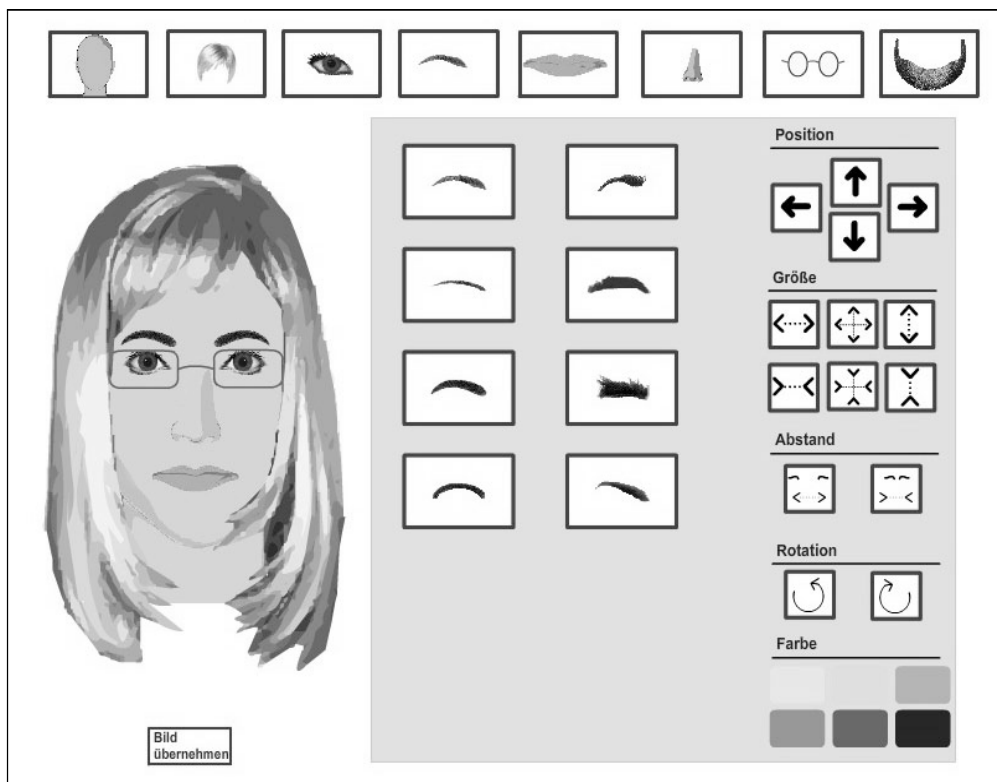

Figure 1. The Avatar Editor with the eyebrow-panel opened

Although participants had some fun modeling their real life partner, a pretest revealed that they expressed enduring concerns about the accurateness of the virtual avatar and got stuck in ruminations about inconsistent details. This finding is consistent with the hypothesis of the "uncanny valley" (Mori, 1982), which states that in some region short of 100% realism, users are jolted by some minor inconsistencies, which completely destroy the illusion of realism. While in several scenarios increased realism indeed might have an impact on believability and immersion, theoretical considerations and the experiences from my pretest led me to the conclusion that in the special case of a virtual spouse, "less is more".

In addition, I did not define the virtual spouse as an avatar (i.e., a representation) of the real life partner, just as I did not define the protagonist as a representation of the participant. The protagonist was rather introduced as "the Simo you can give commands to", and the virtual spouse was introduced as "the romantic partner of the protagonist". Hence, participants were not instructed to act out their current real life relationship - at least not explicitly. Support for this approach can be drawn from the assessment of implicit motives by means of picture story exercises (Schultheiss & Pang, 2007) like the Thematic

Apperception Test (TAT). Although stories written to these pictures usually are written about other persons from a third person's view, valid inferences about the implicit motives of the writer can be drawn. In some coding systems, stories written from the first person's perspective even are discarded (Fivush, 2006; Waters & Waters, 2006).

Besides the resemblance to the real partner, another decision has to be taken concerning the visual fidelity of the virtual spouse. While many other applications of VEs strive for photo realistic visual displays, I argue for the contrary: a symbolic depiction. As already discussed, too many details can lead to disturbances and prevent a successful immersion. A symbolic depiction of the virtual partner, in contrast, decreases feelings of strangeness and inconsistency, and rather provides a blank slate where behavioral and emotional habits can be transferred to (for a detailed discussion, see Chapters 3 and 4). Empirical results give support for this approach. For example, in an extension of Heider and Simmel's (1944) classic study, Barrett, Todd, Miller, and Blythe (2005) could show that motion trajectories from simple geometrical shapes could be correctly classified as activities like chasing, mating, or fighting; and a ball tossing game with very crude stick men elicited strong feelings of exclusion ("cyber-ostracism", Williams, Cheung, & Choi, 2000). Likewise, Sanchez-Vives and Slater (2005) concluded in a review of virtual reality research that "[s]urprisingly, however, there is strong evidence that people respond to relatively crude virtual humans as if they were real people." (p. 335).

To summarize, symbolic virtual agents can be seen as a unique combination of social realism and the necessary indefiniteness which fosters the mechanism of transference. On the one hand, they provide the necessary behavioral reactions and social consequences which are lacking in pure vignettes. On the other hand, their symbolic depiction provides a rather blank slate onto which mental representations can be applied, in contrast to real persons who might distort the process due to their own characteristics.

Parts of the Dissertation and Summary of Findings

The three manuscripts that are part of this dissertation are based on this framework of virtual social environments with autonomous symbolic agents. The manuscripts aimed at exploring the effect of transference of personality and relationship qualities to agents in a virtual environment, and to what extent these environments can be utilized for the investigation of close relationships.

Manuscript I entitled "The challenge of constructing psychologically believable agents" (Chapter 2, manuscript accepted pending minor changes by *Journal of Media Psychology*) is a theoretical article that describes challenges of the implementation of psychological models into autonomous agents. As psychological theories often lack the necessary details for a direct implementation, many agent modelers currently rely on models that are rather marginal in current psychological research, or models that are created *ad hoc* with little theoretical and empirical foundations. The goal of this article was both to raise psychologists' awareness about central challenges in the process of creating psychologically believable agents, and to recommend existing psychological frameworks to the virtual agents community that seem particularly useful for an implementation. Special attention is paid to the Zurich model of social motivation (Bischof, 1993, 2001; Schneider, 2001) a computationally detailed model of basic social motives that seemed particularly useful for an implementation in the agents of Simoland.

Manuscript II entitled „Virtual social environments as a tool for psychological assessment: Dynamics of interaction with a virtual spouse“ (Chapter 3; in press in *Psychological Assessment*) reports about the first empirical study conducted in Simoland. An internet sample of 236 participants, all in a serious relationship for at least 6 months, played Simoland for 15 min. and interacted freely with their virtual spouse and other Simos. No specific scenes were created, as I sought to assess spontaneous and uncontrolled behavior in a free environment. As main results, I could show that both the relationship satisfaction to the real life partner and the intimacy motive of the participants were correlated with the behavior of the protagonist towards the virtual spouse. Specifically, I modeled the intraindividual change in the occurrence of positive vs. negative behaviors (cf., Gottman & Levenson, 1992), and could show that participants with a high relationship satisfaction had a more positive start in the virtual relationship. Additionally, the intimacy motive of participants influenced the persistence of positive behavior: Participants high in intimacy motivation instructed their protagonist to stay positive or even to increase positive behaviors, while protagonists of participants low in intimacy motivation showed a decline in positive behaviors. For the first time, this study could demonstrate that indeed characteristics of the real life romantic relationship are transferred to a virtual relationship.

Manuscript III entitled „Transference of adult attachment dynamics to a virtual spouse“ (Chapter 4; submitted to *Journal of Personality and Social Psychology*) investigates participants' reactions to specific relational situations, theoretically derived from attachment theory. Three different scenarios were created that are supposed to activate the attachment

system: a separation (the virtual spouse has to leave for an uncertain amount of time; the return is uncertain), a conflict (the spouse wrongly accuses the protagonist of infidelity), and a threat (the protagonist learns to know that he or she maybe has a deadly disease). Specific hypotheses about human behaviors in these situations were derived from existing observational studies and it was tested whether the behavior in Simoland is comparable to these results.

I derived three types of game behavior indices from 422 participants who were all in a serious relationship for at least 6 months: behavioral indices, the physical distance between the protagonist and the virtual spouse, and emotion ascriptions. It could be shown that both attachment anxiety and avoidance (measured with the ECR-R, Fraley, Waller, & Brennan, 2000) significantly and meaningfully correlated with all game indices. For example, when the spouse returns after the separation, protagonists of avoidant participants showed a strikingly similar behavior to that of avoidant children in the reunion episode of the strange situation procedure (Ainsworth, Blehar, Waters, & Wall, 1978): Avoidant participants instructed their protagonists to keep a greater distance to the spouse, initiated less interaction overall, and in particular less positive interactions. Furthermore, they did not ascribe an emotional relieve to the protagonist. As further main results, avoidant participants expressed a desire for revenge in response to the conflict, as expected (Mikulincer & Shaver, 2005). When the spouse offered comfort during the threat scene, avoidant participants actively increased the distance between the protagonist and the spouse.

Generally, the results support Fraley and Shaver's (2000) emotional vs. behavioral regulation model of attachment, which proposes that attachment anxiety refers to the motivation to monitor and appraise events that are related to attachment-related issues, and attachment avoidance is supposed to regulate behavioral responses to attachment-related issues. Corresponding to this view, attachment anxiety in this study predicted the negative emotional reaction participants ascribed to their protagonists in response to the separation and the conflict, and behavioral reactions were predicted by attachment avoidance.

To summarize, for the first time this study demonstrates that internal working models of attachment are transferred to a virtual relationship, and that VSEs can be an economic and flexible research tool for the investigation of attachment-related behaviors in different scenarios.

General Discussion

The aim of this dissertation was to explore how virtual environments can be utilized for the investigation of behavior in close relationships. In contrast to the few existing studies conducted in VEs, the focus was on big sample sizes, high controllability through the use of autonomous agents, and an easy and economical administration over the internet. Manuscript II demonstrates meaningful correlations between real-life variables and virtual behavior, and Manuscript III replicated several findings from real-life observational studies. Taken together, the empirical studies provide evidence for the assumption that virtual behavior indeed reflects real behavior, at least under appropriate conditions. Therefore, with this dissertation an important step has been taken to establish VSEs as a versatile research tool for the investigation of the effects of transference, close relationships, and motivational processes.

The application of VSEs as a research tool has several advantages and drawbacks. On the one hand, the initial setup of the environment requires rather high efforts. During this dissertation, about one and a half years have been spent for programming the game framework, implementing a "virtual brain" for the autonomous agents, and optimizing the game for usability and stability. Now that this framework exists, however, it is relatively easy to construct new scenarios or to experimentally vary the behavior of the virtual spouse. Furthermore, data collection and the coding of behavioral indices demanded much less effort compared to a conventional observational study. Data collection was done over the internet, and instead of manually coding hours of video material, behavioral indices could be automatically retrieved by parsing the behavioral protocol with appropriate software. Besides these procedural advantages, scenarios have been created which are hard or impossible to present in the laboratory with real persons.

The use of VSEs is a melting pot of several future technologies and therefore increases the demand of interdisciplinary collaboration. Elaborate agent models are necessary to create believable agents which allow valid conclusions about participants' interactions with them. While psychologists can profit from elaborate environments to build their experiments, designers of robots and embodied conversational agents in turn can benefit from psychologically informed models.

In this dissertation, new ways have been taken that may significantly contribute to future psychological research. While the investigation of behavior in VSEs never will replace classic observational studies in the laboratory or in the field (each has its own advantages,

drawbacks, and areas of application), it might become a standard technique amongst others. Before that will happen, however, the validity of this approach has to be shown. The two empirical studies of this dissertation provide a promising start.

References

- Adobe Systems Inc. (2009). Adobe Flash Player version penetration. Retrieved from http://www.adobe.com/products/player_census/flashplayer/version_penetration.html
- Ainsworth, M., Blehar, M. C., Waters, E., & Wall, S. (1978). *Patterns of attachment: A psychological study of the strange situation*. Hillsdale: Lawrence Erlbaum Associates.
- Andersen, S. M., & Thorpe, J. S. (2009). An IF-THEN theory of personality: Significant others and the relational self. *Journal of Research in Personality, 43*, 163-170.
- Asendorpf, J. B. (2007). *Psychologie der Persönlichkeit [Psychology of personality]*. 4. Auflage. Berlin: Springer.
- Bailenson, J. N., Blascovich, J., Beall, A. C., & Loomis, J. M. (2003). Interpersonal distance in immersive virtual environments. *Personality and Social Psychology Bulletin, 29*, 819-833.
- Baldwin, M. W., & Fehr, B. (1995). On the instability of attachment style ratings. *Personal Relationships, 2*, 247-261.
- Barrett, H. C., Todd, P. M., Miller, G. F., & Blythe, P. W. (2005). Accurate judgments of intention from motion cues alone: A cross-cultural study. *Evolution and Human Behavior, 26*, 313-331. doi:10.1016/j.evolhumbehav.2004.08.015
- Baumeister, R. F., Vohs, K. D., & Funder, D. C. (2007). Psychology as the science of self-reports and finger movements: Whatever happened to actual behavior. *Perspectives on Psychological Science, 2*, 396-403.
- Berk, M., & Andersen, S. M. (2000). The impact of past relationships on interpersonal behavior: Behavioral confirmation in the social-cognitive process of transference. *Journal of Personality and Social Psychology, 79*, 546-562.
- Berk, M., & Andersen, S. M. (2008). The sting of lack of affection: Chronic goal dissatisfaction in transference. *Self and Identity, 7*, 393-412.
- Bischof, N. (1993). Untersuchungen zur Systemanalyse der sozialen Motivation I: Die Regulation der sozialen Distanz - Von der Feldtheorie zur Systemtheorie [On the regulation of social distance - from field theory to systems theory]. *Zeitschrift für Psychologie, 201*, 5-43.
- Bischof, N. (2001). *Das Rätsel Ödipus. Die biologischen Wurzeln des Urkonflikts von Intimität und Autonomie*. [The riddle of Oedipus. The biological roots of the core conflict between intimacy and autonomy]. München: Piper.
- Blascovich, J., Loomis, J., Beall, A. C., Swinth, K. R., Hoyt, C. L., & Bailenson, J. N. (2002). Immersive virtual environment technology as a methodological tool for social psychology. *Psychological Inquiry, 13*, 103-124.
- Bowlby, J. (1980). *Attachment and loss*. New York: Basic Books.
- Brumbaugh, C. C., & Fraley, R. C. (2006). Transference and attachment: How do attachment patterns get carried forward from one relationship to the next? *Personality and Social Psychology Bulletin, 32*, 552-560.

- Brumbaugh, C. C., & Fraley, R. C. (2007). Transference of attachment patterns: How important relationships influence feelings toward novel people. *Personal Relationships, 14*, 513-530.
- Deutsche Shell Holding. (2006). *Jugend 2006. 15. Shell Jugendstudie*. Frankfurt am Main: Fischer.
- Dotsch, R., & Wigboldus, D. H. (2008). Virtual prejudice. *Journal of Experimental Social Psychology, 44*, 1194-1198. doi:10.1016/j.jesp.2008.03.003
- Fivush, R. (2006). Scripting attachment: Generalized event representations and internal working models. *Attachment & Human Development, 8*, 283-289.
- Fraley, R. C. (2007). A connectionist approach to the organization and continuity of working models of attachment. *Journal of Personality, 75*, 1157-1180.
- Fraley, R. C., & Shaver, P. R. (2000). Adult romantic attachment: Theoretical developments, emerging controversies, and unanswered questions. *Review of General Psychology, 4*, 132-154.
- Fraley, R. C., Waller, N. G., & Brennan, K. A. (2000). An item response theory analysis of self-report measures of adult attachment. *Journal of Personality and Social Psychology, 78*, 350-365.
- Frey, A., Blunk, H. A., & Banse, R. (2006). Psi-Land: Paarinteraktionsforschung in einer virtuellen Umgebung [Psi-Land: Investigating interactive behaviour in romantic couples in a virtual environment.]. *Zeitschrift für Sozialpsychologie, 37*, 151-159.
- Frey, A., Hartig, J., Ketzler, A., Zinkernagel, A., & Moosbrugger, H. (2007). The use of virtual environments based on a modification of the computer game Quake III Arena (R) in psychological experimenting. *Computers in Human Behavior, 23*, 2026-2039.
- Furr, R. M. (2009). Personality psychology as a truly behavioral science. *European Journal of Personality, 23*, 369-401.
- Gottman, J. M. (1998). Psychology and the study of marital processes. *Annual Review of Psychology, 49*, 169-197.
- Gottman, J. M., & Levenson, R. W. (1992). Marital processes predictive of later dissolution: Behavior, physiology, and health. *Journal of Personality and Social Psychology, 63*, 221-233.
- Heider, F., & Simmel, M. (1944). An experimental study of apparent behavior. *American Journal of Psychology, 57*, 243-259.
- Klinger, E., Bouchard, S., Legeron, P., Roy, S., Lauer, F., Chemin, I., & Nugues, P. (2005). Virtual reality therapy versus cognitive behavior therapy for social phobia: A preliminary controlled study. *CyberPsychology & Behavior, 8*, 76-88.
- La Guardia, J. G., Ryan, R. M., Couchman, C. E., & Deci, E. L. (2000). Within-person variation in security of attachment: A self-determination theory perspective on attachment, need fulfillment, and well-being. *Journal of Personality and Social Psychology, 79*, 367-384.
- Mallinckrodt, B., & Chen, E. C. (2004). Attachment and interpersonal impact perceptions of group members: A social relations model analysis of transference. *Psychotherapy Research, 14*, 210-230.
- McCall, C., Blascovich, J., Young, A., & Persky, S. (2009). Proxemic behaviors as predictors of aggression towards Black (but not White) males in an immersive virtual environment. *Social Influence, 4*, 138-154.

- McClelland, D. C., Koestner, R., & Weinberger, J. (1989). How do self-attributed and implicit motives differ? *Psychological Review*, *96*, 690-702.
- Mikulincer, M., & Shaver, P. R. (2005). Attachment theory and emotions in close relationships: Exploring the attachment-related dynamics of emotional reactions to relational events. *Personal Relationships*, *12*, 149-168.
- Mori, M. (1982). *The Buddha in the Robot*. Charles E. Tuttle Co.
- Pierce, T., & Lydon, J. E. (2001). Global and specific relational models in the experience of social interactions. *Journal of Personality and Social Psychology*, *80*, 613-631.
- Prager, K. J. (1995). *The psychology of intimacy*. New York: Guilford Press.
- Sanchez-Vives, M. V., & Slater, M. (2005). From presence to consciousness through virtual reality. *Nature Reviews Neuroscience*, *6*, 332-339.
- Saribay, S. A., & Andersen, S. M. (2007). Are past relationships at the heart of attachment dynamics? What love has to do with it. *Psychological Inquiry*, *18*, 183-191.
- Schneider, M. (2001). Systems theory of motivational development. In N. J. Smelser & P. B. Baltes (Eds.), *International Encyclopedia of the Social & Behavioral Sciences* (pp. 10120-10125). Oxford: Elsevier.
- Schultheiss, O. C. (2001). An information processing account of implicit motive arousal. In M. L. Maehr & P. Pintrich (Eds.), *Advances in motivation and achievement (Vol. 12: New directions in measures and methods)* (pp. 1-41). Greenwich: JAI Press.
- Schultheiss, O. C., & Pang, J. S. (2007). Handbook of research methods in personality psychology. In R. W. Robins, R. C. Fraley, & R. F. Krueger (Eds.), *Measuring implicit motives* (pp. 322-344). Guilford Press.
- Sibley, C. G., & Overall, N. C. (2008). Modeling the hierarchical structure of attachment representations: A test of domain differentiation. *Personality and Individual Differences*, *44*, 238-249.
- Slater, M., Guger, C., Edlinger, G., Leeb, R., Pfurtscheller, G., Antley, A., Garau, M., et al. (2006). Analysis of physiological responses to a social situation in an immersive virtual environment. *Presence*, *15*, 553-569.
- Tichon, J., & Banks, J. (2006). Virtual reality exposure therapy: 150-Degree screen to desktop PC. *CyberPsychology & Behavior*, *9*, 480-488.
- Waters, H. S., & Waters, E. (2006). The attachment working models concept: Among other things, we build script-like representations of secure base experiences. *Attachment and Human Development*, *8*, 185-197.
- Williams, K. D., Cheung, C. K. T., & Choi, W. (2000). Cyberostracism: Effects of being ignored over the internet. *Journal of Personality and Social Psychology*, *79*, 748-762.

Chapter 2

The challenge of constructing psychologically believable agents

Felix D. Schönbrodt and Jens B. Asendorpf

Humboldt University Berlin, Germany

Embodied conversational agents (ECAs) are designed to provide a natural and intuitive communication with a human user. One current major topic in agent design consequently is to enhance their believability, often by means of incorporating internal models of emotions or motivations. As psychological theories often lack the necessary details for a direct implementation, many agent modelers currently rely on models that are rather marginal in current psychological research, or models that are created ad hoc with little theoretical and empirical foundations. The goal of this article is both to raise psychologists' awareness about central challenges in the process of creating psychologically believable agents, and to recommend existing psychological frameworks to the virtual agents community that seem particularly useful for an implementation in ECAs. Special attention is paid to a computationally detailed model of basic social motives that seems particularly useful for an implementation: the Zurich model of social motivation.

Introduction

For decades, humans had to speak the language of the machines when they wanted to communicate with them. Starting from the first mechanical calculating machines from the 17th century, where the operators had to understand the internal mechanisms to get valid results, this habit continued till the 1970s, when human still had to “talk” to computers via punch cards (Redin, 2007). A major shift in human-machine interaction took place in the 1980s with the introduction of graphical user interfaces and accompanying features like drag-and-drop, a trash can for the deletion of files, or a desktop (like in reality, cluttered with papers and files). None of these interface features is a necessity for the machine, but enhances usability by referring to well-known work flows from the physical world (e.g. “grabbing a file and throwing it into the trash can”). A preliminary culmination in the evolution towards a more user-centered communication has been reached in the efforts to develop human-like synthetic characters (embodied conversational agents, ECAs), whose purpose is to allow a natural verbal and non-verbal communication (Cassell, Churchill, Prevost, & Sullivan, 2000).

To allow humans a communication to computers that is as natural as possible, it is argued that ECAs should be built upon existing psychological theories about human communication, emotion, and motivation (Gratch & Marsella, 2004). But what can psychology contribute to build more believable embodied conversational agents? As Krämer, Bente, Eschenburg, and Troitzsch (2009) state, up to now there is only little exchange between the virtual agents community employing psychological theories and current psychological research. Although there have been several attempts to implement psychological theories into autonomous agents, many psychological theories lack the necessary details needed for a direct implementation. Software architects therefore have to do a lot of interpretation, extrapolation and “filling the gaps”. Psychological theories largely differ in their level of detail, and during the process of implementation one soon will find some theories to be more suitable than others. Consequently, virtual agent architects sometimes seem to choose their models mainly based on its computability. For example, the most frequently implemented model of emotion is the OCC model by Ortony, Clore, and Collins (1988), a theory which is not the most prominent one in psychological textbooks or current psychological research (Krämer, 2008). Furthermore, often specific psychological knowledge about communication and interactional processes is scarce, and it was concluded

that one has to rely on the intuition of the designers and animators of ECAs (Cassell et al., 2000), or on ad hoc models which are based on dubious data or no data at all (cf. Krämer, 2008).

The current article addresses both the psychologists and the virtual agents community. On the one hand its goal is to increase psychologists' awareness about the shortcomings of many psychological theories when they are to be implemented in autonomous agents and to introduce some key challenges in the construction of ECAs. The example of the action selection problem is introduced to highlight an area where psychological input would be needed, but unfortunately is largely missing. On the other hand, psychological theories in the domains of interpersonal perception and behavioral synchrony are presented as a possible psychological input into the design of ECAs. Finally, the Zurich model of social motivation is presented as a theory that is both psychologically sound and provides detailed information about computational details, which eases potential implementations by the virtual agents community.

Believability

As a goal in the construction of ECAs is a flawless and smooth conversation with human interaction partners, enhancing the believability of ECAs generally is a sensible goal. But what is the scientific concept of believability, beyond the common sense of the word? No final definition of believability has been come up so far, and several fine-grained distinctions of different types of believability have been proposed (e.g., Rose, Scheutz, & Schermerhorn, 2010). Believability can be conceptualized both as a property of the ECA (e.g., special conversational abilities that raise the feeling of believability in most human interaction partners), as well as a property of the perceiver (e.g., the "hardened robotics researcher", for whom it is very unlikely to ascribe mental states to any robot due to his intricate knowledge of the underlying mechanisms; Rose et al., 2010).

For the purpose of this article, we focus on the properties of ECAs that contribute to believability, and we put forward an operational working definition of believability: Believability of an ECA is the extent to which human interaction partners can intuitively communicate with it by applying natural processes of human communication. The numerous processes involved can include the perception of a consistent personality of the ECA (Ortony, 2003), which is expressed through behavior that is consistent with the agents' goals or states of mind, as well as a consistency between verbal and non-verbal

communication (De Rosis, Pelachaud, Poggi, Carofiglio, & Carolis, 2003). Internal models of emotion and motivation should be a promising way to achieve this consistency (see below). Furthermore, the consideration of natural processes of interpersonal perception should increase the feeling of believability. These processes, which all contribute to the impression of believability, are diverse aspects which might well be separately analyzed. However, we would argue that at a higher level of abstraction all these aspects contribute to a “general factor” of believability.

Thus, the general idea of believability is to enhance and ease human-machine interaction by using natural and intuitive codes of human communication. Humans have certain expectations about communicative signals, patterns, and reactions of interaction partners. Believability of an ECA means that humans can apply their usual mental models of communication.

Why should designers of ECAs want to increase the believability of their agents? The ultimate intentions of making agents believable can be very different and include for example (a) better user experiences in games, virtual drama, or arts (“suspension of disbelief”, Bates, 1994); (b) higher impact of cybertherapy or training exercises (e.g. Beutler & Harwood, 2004); (c) higher external validity in virtual social psychology experiments (e.g. Blascovich, Loomis, Beall, Swinth, Hoyt, & Bailenson, 2002); (d) a more effective and robust transmission of information through the use of multiple communicative channels (e.g. Cassell, 2001); or (e) the simulation of psychological theories, when the evaluation of the agents’ believability is the criterium of interest (Wehrle, 1998).

How can believability be achieved? We already mentioned several psychological processes above. Maybe the most discussed approach to believability is the implementation of emotions and motivations into agents (e.g. Becker-Asano & Wachsmuth, 2008; De Rosis et al., 2003; Gratch, 2008; Hudlicka, 2003; Ortony, 2003). However, it has been debated whether human-like *internal processes* are necessary at all, or whether the replication of *surface displays* is sufficient for a believable and effective communication. Krämer, Iurgel, and Bente (2005) argue that to reach the ultimate goal of an ECA - to make the human-computer interaction more intuitive and to manipulate the emotions of the user - it is not necessary to simulate internal processes in terms of an emotion model or motivation model. Instead they propose a conversational function model where emotional expressions are seen as purely instrumental and disconnected from the feeling of emotions (cf. Fridlund, 1991).

In this alternative approach, non-verbal behaviors (like emotional displays) are directly chosen based on their known (and intended) effect on the user, without the need of a simulated emotional state of the agent. By doing so, the realized system would be more effective and easier to implement. In some restricted scenarios this alternative approach might be straightforwardly implemented. In more open scenarios (e.g., in a soft-skills business training simulation), these agents, however, soon will reach their limits as situations will arise that are not covered by the internal database (Ortony, 2003). In such an application scenario, agents who are guided by more general underlying principles presumably produce more consistent and coherent behavior. Accordingly, Gratch and Marsella (2004) argue that internal processes and emotional expressions are closely linked, and that psychologically informed theories about internal processes should form the basis for communicative processes in interactive settings (see also Gratch, 2008).

To be clear, we do not argue that an implementation of human psychological mechanisms is mandatory to achieve an agent's believability – a newly developed “non-human” architecture of an ECA could as well accomplish the same goal, along Krämer et al.'s argumentation. However, as the mind of humans is adopted to interact with other humans, these psychological models and processes presumably are best suited for the task.

In the remainder some key challenges in the construction of ECAs are presented, and psychological theories are presented, whose implementation is promising for the increase of believability.

Action Selection and the Persistence of Behavior

One challenge every designer of agent architectures has to face is the development of a mechanism that decides which specific behavior the agent should initiate in the presence of multiple external or internal driving forces. This decision is also called the problem of “action selection”, and two oversimplified solutions should illustrate the difficulty:

(a) pure dominance of motives: motives are in a fixed hierarchy, for example “flight” always dominates “eating”, which in turn always dominates “mating”. The lower priority motive only can be expressed if all higher priority motives are satisfied.

(b) “the winner takes it all”: the motivation with the momentary highest activation (due to internal or external factors) gains control over behavior.

However, both approaches inadequately deal with the problem of persistence of behavior. For the following examples imagine the simulation of physiological needs in a simulated environment - namely hunger and thirst - which both rise continuously over time

and have to be regularly satisfied. If thirst always dominates hunger, an agent with a slightly higher thirst motivation will stay in the “search-for-water-mode” until its thirst is completely satisfied - even if on its way to the water the most delicious fruits are located which could have been picked up as an opportunity to satisfy its hunger. While this model might work in a few selected conditions, it certainly will not produce a sensible and adaptive behavior in most circumstances. “The winner takes it all” in contrast can lead to an ineffective oscillation of behavior. In the competition of hunger and thirst the agent will drink only as long as the thirst motivation is slightly below the hunger motivation. At this moment, hunger takes control over behavior and directs movement toward the food resource. During travel time, both needs rise, and due to the dithering of behavior both needs will be unsatisfied in the long run.

An ethologically inspired solution to this problem is called a *time sharing mechanism*, first proposed by McFarland (1976). Time sharing describes the ability of an organism to allow low-priority goals to gain temporarily behavioral control even if a higher-priority goal is present. A computational model to achieve time-sharing consists of two mechanisms: inhibition and fatigue. Inhibition occurs when an active motivational system inhibits competing motivations, leading to behavioral persistence. On the other hand, to prevent agents from mindlessly pursuing unreachable goals, a second mechanism, fatigue, is implemented. Fatigue is a dampening factor, which rises whenever specific activities are performed. That means, the longer an activity is performed without reaching its goal the stronger it is damped by fatigue, allowing other motivational systems to take a turn (for computational details of time sharing see Blumberg, 1994; Ludlow, 1980). Behavior controlled by the combination of inhibition and fatigue results in a hysteresis, where both dithering and rigidity of behavior are avoided. The specific amount of behavioral persistence depends on the amount of inhibition and fatigue, resulting in some compromise between behavioral rigidity and behavioral oscillation.

Returning to the question of believability, a well-balanced mechanism of action selection, based on a set of motivations that is reasonable for the ECA's context, should enhance the impression of believability. While this topic is a standard problem each agent architect has to solve, there is only very few coverage in psychological research. Although there is a strong classical tradition about intraindividual motivational conflicts (approach-approach conflicts, approach-avoidance conflicts, etc.; Lewin, 1931), and several contemporary studies that deal with motivational conflict, most of them only investigate the

consequences of those conflicts (e.g. an impaired well-being, e.g. Riediger & Freund, 2008), and not the underlying processes. Furthermore, the majority of these approaches only investigates one-shot decisions or cross-sectional data, and does not deal with the dynamic interplay of ongoing forces that compete for behavioral control. The action selection problem is not so much a problem of a single choice what to do in a concrete situation, but much more concerned with regulating, optimizing and balancing different drives over time. Studies investigating the processes how humans solve and self-regulate these motivational conflicts are rare (e.g. Kumashiro, Rusbult, & Finkel, 2008). In this case, design considerations of virtual agents point to a rather neglected field in psychological research, and could be an inspirational source for future studies.

Interpersonal Perception and Behavioral Synchrony

One main feature of ECAs is the ability to “recognize and respond to verbal and non-verbal input” and “to deal with conversational functions such as turn taking, feedback, and repair mechanisms” (Cassell, 2000, p. 70). Some ECAs have the ability to sense human users in the real environment by means of cameras or microphones. For example, the virtual agent “MAX” (Kopp, Gesellensetter, Krämer, & Wachsmuth, 2005) perceives and tracks multiple persons standing in front of him with a camera. “REA” (Cassell, 2001) for instance interprets conversational pauses smaller than 500 ms such as the user wants some (non-verbal) feedback. The ability to process these sensory informations and to translate them into a meaningful and coherent communication, which, in turn, enhances believability, needs a detailed knowledge about human communication processes and interpersonal perception.

What can current psychological research contribute to the question of interpersonal perception? Unfortunately, most empirical work is based on aggregated measures of behavior and does not provide enough information about the processes, dynamics, or timing of communicative phenomena which would be necessary for a top-down implementation of these theories. Advanced models in current research of personality and interpersonal judgments, however, explicitly investigate the role of cues in interpersonal perception and, for example, seek to find which specific behavioral cues predict personality traits or which specific cues or cue-preference combinations predict interpersonal attraction. For example, Back, Schmukle, and Egloff (in press) investigated attraction at zero acquaintance in an extensive design with 2628 dyads. They could show how perceptible cues of the target affect

attraction in general (e.g. pleasantness of voice, “babyfacedness”, energy of body movements) and how preference similarities between perceiver and target predicted relational attraction. These findings can be of great value for the construction of ECAs, as many encounters in human-machine interactions are at zero acquaintance.

Other basic properties in non-verbal communication are the phenomena of synchronization and mimicry. Research concerning affective and behavioral synchronization demonstrates its importance for the adaptivity and quality of communicative processes. In the investigation of client-therapist dyads, Ramseyer and Tschacher (2008) found that synchrony (measured as the energy of body movements) predicted both the perceived quality of the therapeutical relationship on a micro level (within each session) as well the therapeutical success on a macro level. Furthermore, in a non-clinical population, Chartrand and Bargh (1999) demonstrated that non-verbal mimicry (the “chameleon effect”) served as a cause of interpersonal rapport and empathy, and consequently led to a smoother interaction. Comparable results could be found in opposite-sex dyads, where synchrony of behavioral patterns predicted interpersonal attraction (Grammer, Kruck, & Magnusson, 1998). Complementary, research about disordered communication in patients can clarify what ECAs should avoid as much as possible: Steimer-Krause, Krause, and Wagner (1990), for example, could show that a denial of affective synchronization (a behavior frequently found in schizophrenic patients) is an effective way to induce negative affect in the interaction partner. This and other findings could be a caveat for affective computing: Maybe no emotional display is sometimes better than a wrong emotion at the wrong time (see also Cassell, Bickmore, Campbell, Vilhjalmsson, & Yan, 1999, for the importance of timing in conversations).

To the authors knowledge only two studies by Bailenson and colleagues are present about the effect of agent-initiated mimicry: Agents that imitated the user’s head position with a delay of 4 seconds were evaluated more persuasive and likable (Bailenson & Yee, 2005). This effect, however, only was true when participants did not explicitly detect the mimicry (Bailenson, Yee, Patel, & Beall, 2008). Although the implementation of mimicry in these studies was relatively simple, the study demonstrates the potential of this largely unutilized phenomenon for ECAs non-verbal communication.

The Zurich Model of Social Motivation

The purpose of this section is to reintroduce a model that might fulfill the needs of both worlds, the psychological world and the virtual agent world, providing both a psychologically sound theory of basic social motivations and the computational details that are needed to implement the theory without too much of interpretation and reconstruction: the Zurich model of social motivation (referred to as *ZM* in the remaining paper; Bischof, 2001; Gubler & Bischof, 1991; Schneider, 2001). The *ZM* has some roots in Bowlby's attachment theory (Bowlby, 1980). As attachment theory is formulated in terms of control systems theory and information processing, it is supposed to be very suitable for simulations and several architectures have been developed based on attachment theory (Bischof, 1975; Horswill, 2008; Petters & Waters, 2010).

However, the *ZM* goes far beyond attachment theory concerning the broadness of social phenomena it covers. It claims to describe dynamic motivated behavior from a developmental, evolutionary, and systems theory perspective, not only in infants, but also in adolescents and adults. Furthermore, the *ZM* not only incorporates security seeking behavior, but postulates three phylogenetically old motivational systems: (a) the security system, (b) the arousal system and (c) the autonomy system (see Figure 1). The autonomy system furthermore is divided into three phylogenetically distinguishable motives: power, prestige and achievement. All of these motivational systems are modeled as feedback control cycles which compare an internal set point with an actual value that is perceived through specific detectors. The discrepancy between actual value and set point is the resulting motivational activation.

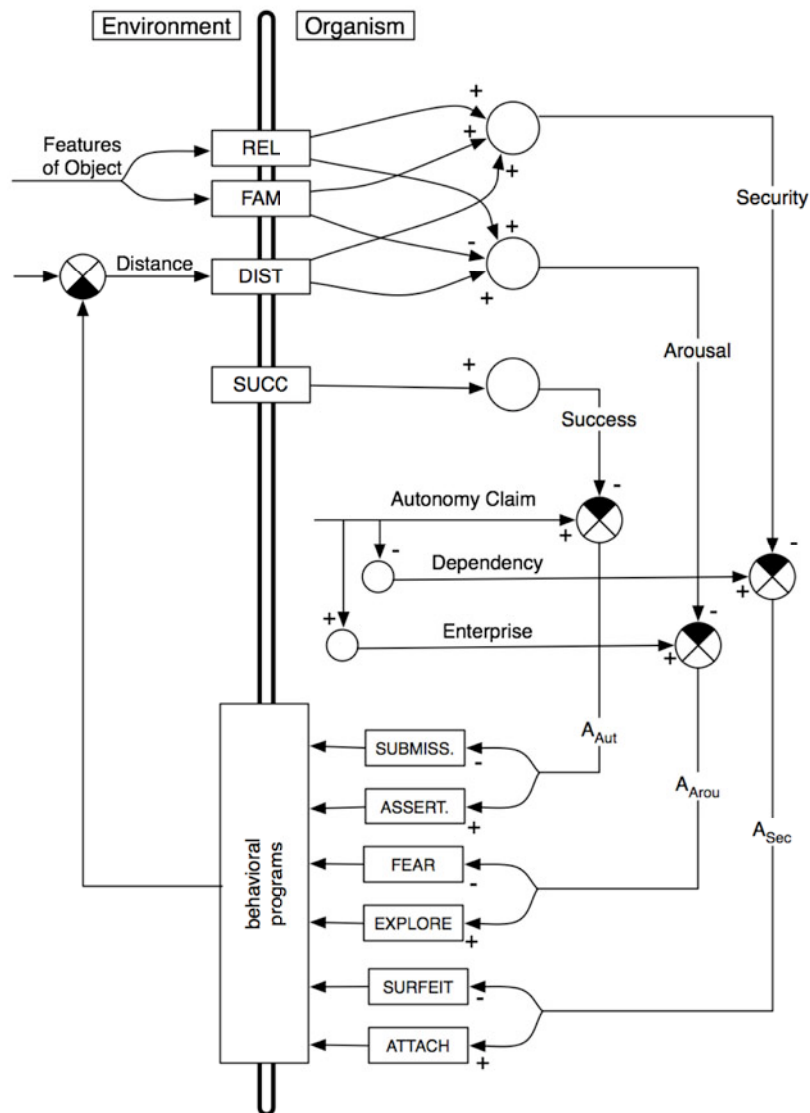

Figure 1: A simplified version of the Zurich model of social motivation (adapted from Bischof, 1993). REL= relevance, FAM = familiarity, DIST = distance, SUCC = success, AAut= activation of autonomy system, AArou= activation of arousal system, ASec= activation of security system.

The security system is a formalization and expansion of the attachment system (Bowlby, 1980) and ensures that the contact to care givers does not get lost. For that purpose, the security system compares the actual value of felt security with an internal set point, called dependency. The ZM clearly defines the environmental cues that influence the actual value. In the case of security it depends on three perceivable cues of other objects: their familiarity, their distance, and their relevancy (a measure of the potency of the object to alter a situation; it is highest for mature adults, medium for less potent siblings and low for inanimate objects like a teddy bear). These three input variables are combined multiplicatively, resulting in the actual value of felt security. Therefore maximum felt security

is achieved, when a familiar and relevant conspecific (e.g. the mother) is nearby. If the actual value falls short of the set point the organism is in a state of security appetite, and thus proximity seeking behavior is initiated. However, if the actual value exceeds the set point, the organism feels an overabundance of security (i.e. security aversion) and surfeit behavior is triggered - a situation that is typically present in puberty. All other motivational control systems are modeled accordingly. The ZM not only describes these core control cycles, but also postulates interconnections between those systems as well as a coping system (not displayed in Figure 1), which gets in charge whenever a motivational activation does not get reduced for a longer time (Gubler & Bischof, 1993).

The scope of the article is not to elaborate the computational details of the model, as these are described in detail in the original publications. However, some examples are given to demonstrate the fine grained level of the model, which goes far beyond most other psychological models of motivation:

(a) action selection: The ZM proposes two types of hystereses to deal with the problem of action selection. Concerning the basic motivational systems a hysteresis with an implied hierarchy of motives is assumed (e.g., an aversion of arousal always has higher priority than an aversion of security; Gubler & Bischof, 1993). Concerning the autonomy system, a more sophisticated cusp catastrophe is proposed (and mathematically described) to model the dynamics of hierarchic encounters, where two opponents reciprocally build up an autonomy claim until the claim of one collapses and the hierarchy is stabilized again (Bischof, 1996).

(b) Interpersonal perception: The sensory inputs of all motivational systems are clearly defined. In an ECA with visual capabilities (e.g. MAX, Kopp et al., 2005), all sensors theoretically could be implemented. Face detection algorithms in combination with a database that records the overall duration of interactions could form the familiarity sensor. Other face detection mechanisms that distinguish facial features could discriminate adults and children as a first approximation to detect the relevance. Other facial features for relevance/dominance could include a prominent chin, body postures, or gaze direction (Hall, Coats, & LeBeau, 2005).

Formulas for many other scenarios are provided as well: What happens if multiple familiar objects are nearby - are two moderately familiar persons better than one highly familiar? How is physical distance related to psychological distance? Is the set point always constant or can it be influenced?

Example Applications

In the following section, two implementations of the ZM will be shortly presented. For details of the implementations and the empirical results, please refer to the original articles referenced.

Dynamic emotional expressions: The varieties of smiling. Most implementations of emotions are based on some kind of appraisal theories, with the OCC model of emotions (Ortony et al., 1988) as the most prominent theory. This model computes a discrete emotion based on the current appraisal of the situation and internal factors, which then is expressed as a “fixed action pattern” by the agent (Gratch, 2008). There are some other approaches, like the WASABI architecture by Becker-Asano and Wachsmuth (2008) who implemented a continuous model of emotions based on the PAD space (Pleasure - Arousal - Dominance). However, when it comes to the expression of the emotion, the continuous emotional space still is mapped onto discrete emotional categories, and the agent expresses the prerecorded emotion with the highest likelihood. This reduces the believability of the agent because evolving appraisals of the situation or mixed emotions get lost (De Rosis et al., 2003; Gratch, 2008). Although the component process theory developed by Scherer and colleagues (Scherer, Schorr, & Johnstone, 2001) in principle describes the dynamic evolution of an emotional expression through the various stages of appraisal, this dynamic approach has not yet been implemented extensively (see, however, Paleari, Grizard, & Lisetti, 2007).

The ZM primarily pronounces the self-regulatory function of emotions, as emotions are only supposed to occur when the primary motivational reaction does not lead to a reduction of the motivational tension. In this case, some sort of coping has to take place, and emotions are supposed to be internal signals to activate and direct the coping system. Although the communicative aspect in this view is rather secondary, a specific mapping from internal motivational indices to facial expressions (action units) is made (Bischof, 1996). While some of these mappings show some similarities to Scherer’s system (e.g. arousal appetite shares some attributes with Scherer’s novelty check), others are hard to compare as the ZM has a stronger focus on dynamics of internal variables.

In one case the ZM makes particular detailed and explicit predictions: it proposes seven varieties of smiling (Bischof, 1996), discussing the fact that smiling is not always an indicator for joy or happiness. The ZM predicts that smiling occurs whenever the claim of autonomy is reduced (i.e., the first derivative of the autonomy claim is negative). Based on

this assumption at least seven different types of smiling can be differentiated, corresponding to seven situations where the claim of autonomy is reduced. To display the facial expression the strength of the computed motivational indexes is directly mapped to the contraction of specific facial muscles. This also implies that the progression of the smile is not pre-scripted, but in fact dynamically responds to changing environmental inputs. Depending on the motivational system the relaxation of the autonomy claim can result in a trustful smile, smile of relief, embarrassed smile, anxious smile, surprised smile, superior smile, or inferior smile. In the case of the inferior smile, for example, the former claim of autonomy collapses when in a hierarchical fight the inferior opponent withdraws. Each of the smiling types is clearly defined in terms of internal states (e.g., the set points of the security or autonomy system) and external signals that trigger the smile (e.g., the appearance of an unfamiliar person).

Borutta, Sosnowski, Zehetleitner, Bischof, and Kühnlitz (2009) implemented these seven types of smiling in animated avatar faces. In an evaluation study they could demonstrate that participants could classify the type of smiling in the resulting emotional video sequences significantly better than chance, supporting the plausibility of the proposed model of smiling and the underlying motivational dynamics. To the author's knowledge, this is one of the first implementations where continuous internal variables are dynamically mapped onto facial muscles (cf., however, Krumhuber, Manstead, & Kappas, 2007, for an evaluation of the dynamics of smiling). While the resulting "smiling head" is not yet a mature ECA at all (as sensory functions and conversational features are missing), the research demonstrates how the ZM can add believability and serves as a viable model for implementation in virtual agents.

Psychological assessment in virtual worlds: How do you treat your virtual spouse? In another project, several motivated agents were designed to interact in a multi-agent environment. The purpose of this study was to assess the participants' behavior towards his or her "virtual spouse" in the context of a larger study investigating romantic relationships (Schönbrodt & Asendorpf, in press). The simulation was presented as an online, interactive computer game where the participant could control one of the agents. In the story of the computer game, the user-controlled agent has a spouse. They are living in a community ("Simoland") together with some other motivated agents, and several scripted events take place during the 15 minutes of game play. The autonomous agents are controlled by a simplified version of the ZM and have a security system to seek contact to familiars (with associated behaviors like kissing, smooching, or talking about their relationship), an

arousal system to contact moderately familiar agents (e.g. dancing together, hearing music), and the non-social motives to regularly satisfy hunger and thirst. Due to the motivated nature of the agents, “life goes on” in Simoland, regardless whether the user interacts or not. The user can initiate more than 30 different behaviors or interactions, and from the resulting course of the game a diversity of game indices can be calculated for diagnostic purposes.

In this application, the motivated agents were not the aim of the investigation but rather provided a background for a new type of personality assessment. Although their conversational capabilities are very limited (e.g., activities and dialogs are displayed by symbols), participants really got involved into the game and developed an affection for the agents. In a pretest ($n=19$) we asked participants whether they experienced an emotional moment during the game and asked them to describe it in an open-ended question. The majority of participants did so, and answers like “When Lisa started to flirt with my husband, I really got jealous. I tried to distract her, so that she stopped flirting” supported the believability of the agents.

Concluding Remarks on the Zurich Model of Social Motivation

In comparison to other psychological models of motivation and emotion, the ZM has the unique feature of an explicit mathematical and computational base. Only very few other psychological theories have a comparable mathematical grounding (e.g. the “dynamics of action” approach, Atkinson & Birch, 1970). However, they usually are limited to a very narrow domain (e.g. achievement motivation).

In comparison to many other models of motivation developed from the agents community, an advantage of the ZM is its sound psychological foundation. It claims to incorporate all basic social motivations of humans, a claim which could be empirically supported (Schönbrodt, Unkelbach, & Spinath, 2009). Therefore, if the goal of a researcher is to equip his or her agents with social motivations, the ZM can serve as an integrative and rather exhaustive model.

A potential drawback of the model, however, is that many publications about it are in German language only. Concerning the validity of the ZM, Gubler, Paffrath, and Bischof (1994) could predict participants' behavior in a space ship simulator by modeling their motivational dynamics with the ZM. In an English publication, Schönbrodt et al. (2009) could show that questionnaire scales assessing the set points of the motivational systems are significantly related to real-life outcomes; and, as described above, Borutta et al. (2009) could show that avatar smiles produced by the ZM could be correctly categorized (for other

English publications, see Bischof, 1975; Borutta et al., 2009; Gubler & Bischof, 1991; Schneider, 2001). Given the complexity of the ZM, however, numerous future validation studies are needed to further explore the validity of the model.

Another potential problem is the behavioral output of the model (see “behavioral programs” in Figure 1). While the model is very detailed and explicit about the generation of motivations, it is rather limited concerning the precise behavioral programs that should be triggered by certain motivational states. Nonetheless, from our point of view the model seems to be a good starting point for the implementation of social motives into autonomous agents.

Conclusion

In this article it is argued that psychological models of motivation, emotion, interpersonal perception, and non-verbal communication can enrich virtual agents by enhancing their believability. But it is not only the virtual agents community that can benefit from psychological theories - the embodiment of psychological theories into virtual agents can be a fruitful step in the process of theory construction and testing in psychology as well. As Karl Grammer states, “much [about psychology] can be learned from reverse engineering” (Schönbrodt, 2007), and many possibilities to improve psychological theories become apparent when one tries to implement them. We hope that this article might serve as a starting point for interested psychologists as well as an inspiration for the development of psychologically more believable agents.

References

- Atkinson, J. W., & Birch, D. (1970). *The dynamics of action*. Oxford, England: John Wiley.
- Back, M., Schmukle, S. C., & Egloff, B. (in press). A closer look at first sight: Social relations lens model analysis of personality and interpersonal attraction at zero acquaintance. *European Journal of Personality*.
- Bailenson, J., & Yee, N. (2005). Digital chameleons. *Psychological Science*, *16*, 814-819.
- Bailenson, J., Yee, N., Patel, K., & Beall, A. (2008). Detecting digital chameleons. *Computers in Human Behavior*, *24*, 66-87.
- Bates, J. (1994). The role of emotion in believable characters. *Communications of the ACM*, *37*, 122-125.
- Becker-Asano, C., & Wachsmuth, I. (2008). Affect simulation with primary and secondary emotions. *Lecture Notes in Computer Science*, *5208*, 15-28.
- Beutler, L., & Harwood, T. (2004). Virtual reality in psychotherapy training. *Journal of Clinical Psychology*, *60*, 317-330.
- Bischof, N. (2001). *Das Rätsel Ödipus. Die biologischen Wurzeln des Urkonflikts von Intimität und Autonomie. [The riddle of Oedipus. The biological roots of the core conflict between intimacy and autonomy]*. München: Piper.
- Bischof, N. (1975). A systems approach toward the functional connections of attachment and fear. *Child Development*, *46*, 801-817.
- Bischof, N. (1996). Untersuchungen zur Systemanalyse der sozialen Motivation IV: Die Spielarten des Lächelns und das Problem der motivationalen Sollwertanpassung [The varieties of smiling and the problem of motivational adjustment]. *Zeitschrift für Psychologie*, *204*, 1-40.
- Blascovich, J., Loomis, J., Beall, A. C., Swinth, K. R., Hoyt, C. L., & Bailenson, J. N. (2002). Immersive virtual environment technology as a methodological tool for social psychology. *Psychological Inquiry*, *13*, 103-124.
- Blumberg, B. (1994). *Action-selection in Hamsterdam: Lessons from ethology*. Paper presented at the Third Conference on the Simulation of Adaptive Behavior, Cambridge, MA.
- Borutta, I., Sosnowski, S., Zehetleitner, M., Bischof, N., & Kühnlenz, K. (2009). *Generating artificial smile variations based on a psychological system-theoretic approach*. Paper presented at the 18th IEEE International Symposium on Robot and Human Interactive Communication (Ro-Man), Toyama, Japan.
- Bowlby, J. (1980). *Attachment and loss*. New York, NY, US: Basic Books.
- Cassell, J., Bickmore, T., Campbell, L., Vilhjalmsson, H., & Yan, H. (1999). Conversation as a system framework: Designing embodied conversational agents. In J. Cassell, E. Churchill, S. Prevost, & J. Sullivan (Eds.), *Embodied conversational agents*. Cambridge: MIT Press.
- Cassell, J., Churchill, E., Prevost, S., & Sullivan, J. (2000). *Embodied conversational agents*. Cambridge: MIT Press.

- Cassell, J. (2000). More than just another pretty face: Embodied conversational interface agents. *Communications of the ACM*, 43, 70-78.
- Cassell, J. (2001). Embodied conversational agents: Representation and intelligence in user interfaces. *AI Magazine*, 22, 67-83.
- Chartrand, T., & Bargh, J. (1999). The chameleon effect: The perception-behavior link and social interaction. *Journal of Personality and Social Psychology*, 76, 893-910.
- De Rosis, F., Pelachaud, C., Poggi, I., Carofiglio, V., & Carolis, B. (2003). From Greta's mind to her face: Modelling the dynamics of affective states in a conversational embodied agent. *International Journal of Human-Computer Studies*, 1-2, 81-118.
- Fridlund, A. J. (1991). Evolution and facial action in reflex, social motive, and paralanguage. *Biological Psychology*, 32, 3-100.
- Grammer, K., Kruck, K., & Magnusson, M. (1998). The courtship dance: Patterns of nonverbal synchronization in opposite-sex encounters. *Journal of Nonverbal Behavior*, 22, 3-29.
- Gratch, J. (2008). True emotion vs. social intentions in nonverbal communication: Towards a synthesis for embodied conversational agents. *Lecture Notes in Computer Science*, 4930, 181-197.
- Gratch, J., & Marsella, S. (2004). A domain-independent framework for modeling emotion. *Cognitive Systems Research*, 5, 269-306.
- Gubler, H., & Bischof, N. (1993). Untersuchungen zur Systemanalyse der sozialen Motivation II: Computerspiele als Werkzeug der motivationspsychologischen Grundlagenforschung [Computer games as a tool for basic research on motivation]. *Zeitschrift für Psychologie*, 201, 287-315.
- Gubler, H., & Bischof, N. (1991). A systems theory perspective. In M. E. Lamb & H. Keller (Eds.), *Infant development: Perspectives from German-speaking countries* (pp. 35-66). Hillsdale, NJ, England: Lawrence Erlbaum Associates, Inc.
- Gubler, H., Paffrath, M., & Bischof, N. (1994). Untersuchungen zur Systemanalyse der sozialen Motivation III: Eine Ästimationsstudie zur Sicherheits- und Erregungsregulation während der Adoleszenz [An estimation study of security and arousal regulation during adolescence]. *Zeitschrift für Psychologie*, 202, 95-132.
- Hall, J., Coats, E., & LeBeau, L. (2005). Nonverbal behavior and the vertical dimension of social relations: A meta-analysis. *Psychological Bulletin*, 131, 898-924.
- Horswill, I. (2008). *Attachment and cognitive architecture*. Paper presented at the 2008 AAAI Spring Symposium.
- Hudlicka, E. (2003). To feel or not to feel: The role of affect in human-computer interaction. *International Journal of Human-Computer Studies*, 59, 1-32.
- Kopp, S., Gesellensetter, L., Krämer, N., & Wachsmuth, I. (2005). A conversational agent as museum guide-Design and evaluation of a real-world application. *Lecture Notes in Computer Science*, 3661, 329-343.
- Krämer, N., Bente, G., Eschenburg, F., & Troitzsch, H. (2009). Embodied conversational agents. *Social Psychology*, 1, 26-36.

- Krämer, N., Iurgel, I., & Bente, G. (2005). *Emotion and motivation in embodied conversational agents*. Paper presented at the Proceedings of the Symposium "Agents that want and like", Artificial Intelligence and the Simulation of Behavior (AISB) 2005, Hatfield.
- Krämer, N. C. (2008). *Soziale Wirkungen virtueller Helfer. Gestaltung und Evaluation von Mensch-Computer-Interaktion [Social effects of virtual assistants]*. Stuttgart: Kohlhammer.
- Krumhuber, E., Manstead, A., & Kappas, A. (2007). Temporal aspects of facial displays in person and expression perception: The effects of smile dynamics, head-tilt, and gender. *Journal of Nonverbal Behavior, 31*, 39-56.
- Kumashiro, M., Rusbult, C., & Finkel, E. (2008). Navigating personal and relational concerns: The quest for equilibrium. *Journal of Personality and Social Psychology, 95*, 94-110. doi: 10.1037/0022-3514.95.1.94
- Lewin, K. (1931). Environmental forces in child behavior and development. In C. Murchison (Ed.), *Handbook of child psychology* (pp. 94-127). Worcester, Mass: Clark University Press.
- Ludlow, A. (1980). The evolution and simulation of a decision maker. In F. Toates & T. Halliday (Eds.), *Analysis of Motivational Processes*. London: Academic Press.
- McFarland, D. J. (1976). Form and function in the temporal organisation of behavior. In P. Bateson & R. Hinde (Eds.), *Growing points of ethology* (pp. 55-93). Cambridge University Press.
- Ortony, A. (2003). On making believable emotional agents believable. In R. Trappl, P. Petta, & S. Payr (Eds.), *Emotions in humans and artifacts* (pp. 189-212).
- Ortony, A., Clore, G. L., & Collins, A. (1988). *The cognitive structure of emotions*. New York: Cambridge University Press.
- Paleari, M., Grizard, A., & Lisetti, C. (2007). Adapting psychologically grounded facial emotional expressions to different anthropomorphic embodiment platforms. In *Proceedings of the 20th Florida Artificial Intelligence Research Society FLAIRS 2007 Annual Conference on Artificial Intelligence, Florida*.
- Petters, D., & Waters, E. (2010). *AI, attachment theory and simulating secure base behaviour: Dr. Bowlby meet the Reverend Bayes*. Manuscript submitted for publication.
- Ramseyer, F., & Tschacher, W. (2008). Synchrony in dyadic psychotherapy sessions. In S. Vrobel, O. E. Rössler, & T. Marks-Tarlow (Eds.), *Simultaneity: Temporal structures and observer perspectives* (pp. 329-347). Singapore: World Scientific.
- Redin, J. (2007). A brief history of mechanical calculators. Retrieved from <http://www.xnumber.com/xnumber/mechanical1.htm>
- Riediger, M., & Freund, A. (2008). Me against myself: Motivational conflicts and emotional development in adulthood. *Psychology and Aging, 23*, 479-494.
- Rose, R., Scheutz, M., & Schermerhorn, P. (2010). Towards a conceptual and methodological framework for determining robot believability. *Interaction Studies, 11*, 314-335.
- Scherer, K. R., Schorr, A., & Johnstone, T. (2001). *Appraisal processes in emotion: Theory, methods, research*. Oxford University Press, USA.

- Schneider, M. (2001). Systems theory of motivational development. In N. J. Smelser & P. B. Baltes (Eds.), *International Encyclopedia of the Social & Behavioral Sciences*. Oxford: Elsevier.
- Schönbrodt, F. D. (2007). Interview mit Prof. Dr. Karl Grammer. *Zeitschrift für Medienpsychologie*, 4, 160-161.
- Schönbrodt, F. D., & Asendorpf, J. B. (in press). Virtual social environments as a tool for psychological assessment: Dynamics of interaction with a virtual spouse. *Psychological Assessment*.
- Schönbrodt, F. D., Unkelbach, S., & Spinath, F. M. (2009). Broad motives in short scales: a questionnaire for the Zurich Model of social motivation. *European Journal of Psychological Assessment*, 25, 141-149.
- Steimer-Krause, E., Krause, R., & Wagner, G. (1990). Interaction regulations used by schizophrenic and psychosomatic patients: Studies on facial behavior in dyadic interactions. *Psychiatry: Journal for the Study of Interpersonal Processes*, 53, 209-228.
- Wehrle, T. (1998). *Motivations behind modeling emotional agents: Whose emotion does your robot have*. Paper presented at the Grounding Emotions in Adaptive Systems. Zurich: 5th International Conference of the Society for Adaptive Behavior Workshop Notes (SAB'98), Zurich, Switzerland.

Chapter 3

Virtual social environments as a tool for psychological assessment: Dynamics of interaction with a virtual spouse

Felix D. Schönbrodt and Jens B. Asendorpf

Humboldt University Berlin, Germany

Computer games are advocated as a promising tool bridging the gap between the controllability of a lab experiment and the mundane realism of a field experiment. At the same time, many authors stress the importance of observing real behavior instead of asking participants about possible or intended behaviors. In this article we introduce an online virtual social environment, which is inhabited by autonomous agents including the virtual spouse of the participant. Participants can freely explore the virtual world and interact with any other inhabitant, allowing the expression of spontaneous and unprompted behavior. We investigated the usefulness of this game for the assessment of interactions with a virtual spouse and their relations to intimacy and autonomy motivation as well as relationship satisfaction with the real life partner. Both the intimacy motive and the satisfaction with the real world relationship showed significant correlations with aggregated in-game behavior, which shows that some sort of transference between the real world and the virtual world took place. In addition, a process analysis of interaction quality revealed that relationship satisfaction and intimacy motive had different effects on the initial status and the time course of the interaction quality. Implications for psychological assessment using virtual social environments are discussed.

Introduction

In a perfect psychological study, the researcher is able to maximize both external and internal validity. In reality, however, psychological studies often weight one of these two validity criteria more than the other. On the one extreme, an experiment can be set up in a laboratory with highly controllable conditions and clear inferences of causal relations, but with a highly artificial environment that reduces external validity. On the other extreme, one can perform a field study with high ecological validity but low controllability and internal validity. Computer games and virtual environments occupy an intermediate position and are advocated as promising tools in psychological research and assessment to bridge both extremes, providing a unique combination of both mundane realism and experimental control (Blascovich, Loomis, Beall, Swinth, Hoyt, & Bailenson, 2002). Therefore, the investigation of human behavior in a naturalistic, virtual social environment (VSE) is promising where all characters behave and interact under experimental control. Other characters are implemented as active, autonomous agents, with which participants can interact. Although some researchers already investigated social behavior in virtual environments (e.g., Frey, Blunk, & Banse, 2006; McCall, Blascovich, Young, & Persky, 2009), to our knowledge no such study has been conducted with autonomous agents that allow rather rich social interactions. From an implementation of a VSE we expect two main advantages: (a) an effortless observation of behavior with automatic logging, and (b) a rather implicit measurement that operates on a contextually embedded and naturalistic level (in contrast, e.g., to reaction times in priming studies or Implicit Association Tasks, Greenwald, McGhee, & Schwartz, 1998). Using VSEs, research scenarios can be tackled that can hardly be solved with conventional methods like self-report measures, laboratory studies, or interviews.

This article has two objectives: on the one hand, we want to introduce VSEs as a general tool for the examination of social interactions, and we report considerations which guided us in the implementation of “Simoland”, a VSE which was built to investigate a participant's behavior towards his or her virtual spouse. On the other hand, we illustrate the potentials and limits of such an approach by an empirical study investigating how interpersonal motives and relationship satisfaction shape the behavior in Simoland.

In the remainder of the article we (a) discuss features and problems of VSEs, (b) introduce our actual implementation “Simoland”, and (c) report a study that investigates the

influence of “real world” relationship satisfaction, intimacy motive, and autonomy motive on participants’ behavior towards a virtual spouse who lives in Simoland.

Features and Problems of Open Virtual Social Environments (VSEs)

In the following section some general thoughts on the design of VSEs are made. An early decision has to be made concerning the technical realization. In the construction of a VSE, a trade-off exists between the technical effort ensuring a high fidelity of the virtual environment, for example with head-mounted displays or haptic feedback gloves, and the applicability of the computer test in terms of easiness, coverage, and interoperability on different systems. Recent research has shown that the amount of technical immersion is not necessarily connected to the subjective feeling of presence (“being there in the virtual world”). For example, visual realism does not seem to be a required factor for presence (Sanchez-Vives & Slater, 2005), and ordinary PC monitors have been proven to work as well as a 150-degree semi-immersive curved screen in a therapeutic setting (Tichon & Banks, 2006). Concerning the interaction with virtual characters, humans are apparently capable of processing symbolic representations of people in almost the same manner as real ones, or as Sanchez-Vives and Slater (2005) state in their comment on a virtual exposure therapy of social anxiety: „Surprisingly, however, there is strong evidence that people respond to relatively crude virtual humans as if they were real people“ (p. 335).

Some problems arise in environments where the participants can freely choose where to go and what to. For example, in most environments the participant does not see the entire world at once, which poses the problem that the participant might miss information and events, which, however, are intended to be seen. Therefore, if special scenes are used to induce an experimental manipulation, it has to be made sure that the participant actually perceives the information. In the current implementation of Simoland, special “cut scenes” are used in such cases. Black bars appear on the top and bottom of the screen, and the player cannot interact with the other characters (“Simos”) any more. Subsequently, all relevant Simos walk to pre-scripted positions where the scripted scene takes place as soon as all needed actors are on stage. In other cases, it becomes night (the screen gets dark in a rapid sundown), and on awakening all characters are at a new place where something important happens. Cut scenes of this kind can be used to reset the game to fixed states for all participants, introducing some amount of control and replicability in spite of the generally unrestricted nature of the setting.

However, cut scenes cannot control for the psychological carry-over effects that the participants may experience during the game. For example, if one participant starts a harsh dispute with the spouse while another participant is engaged in kissing and caressing, both will experience the next scene in a different light, even if a cut scene reseted the physical positions and environmental properties. This non-independence of behavioral acts is both an inherent, unavoidable feature and a possible problem of open environments; it reflects what happens in the process of real world behavior that is largely non-independent as well.

What Can Be Measured in Virtual Social Environments?

What is measured in virtual social environments is participants' behavior, just as in any other controlled setting. While behavior in most psychological studies serves as a dependent variable that is predicted by person factors (e.g. attitudes or motives) or situational factors, behavior can also serve as an independent variable that refers to internal states or traits of individuals. Accordingly, VSEs can be employed in two kinds of research questions: (a) What consequences do certain psychological characteristics and situational variations have on the behavior in VSEs, and (b) what tells us the behavior in VSEs about psychological constructs and real world behavior of the participants?

In the case of behavioral assessment as a psychological test, we would argue that the test operates at a semi-implicit level. While the labels “implicit-explicit” are quite common for the description of psychological measures, in fact several dimensions underlie this distinction (De Houwer, Teige-Mocigemba, Spruyt, & Moors, 2009; Fazio & Olson, 2003; Greenwald & Banaji, 1995; McClelland, Koestner, & Weinberger, 1989). Implicit measures can be defined as measurement outcomes that are produced “in the absence of certain goals, awareness, substantial cognitive resources, or substantial time” (De Houwer et al., 2009, p. 350). According to that definition and following the procedure of De Houwer et al. (2009), in the following section we analyse VSEs concerning their “implicitness” along several categories.

Fixed vs. free response set. While forced-choice Likert-type questionnaires on the one extreme have a completely fixed and restricted set of possible responses, a free association session in psychotherapy would mark the other extreme of a free response set. Only few assessment methods use a completely free response set, like free text production in TAT-like measures. In Simoland, the behavioral options are fixed. However, both the choice and the timing of these behaviors are unrestricted: Participants can choose how often they

interact with their virtual spouse (they can even ignore her or him at all), and there are always more behavioral options available than can be enacted in a particular scene.

Presence of goals. Most psychological assessments measure cued responses where explicit tasks or social expectations are present concerning the “what” and “how” of behavior. On the other hand, implicit motive measures from the TAT-tradition, for example, focus on operant behavior (McClelland et al., 1989; Schultheiss, 2001), where the respondent is rather unrestricted concerning content, style and amount of responses. In our current study, participants were encouraged to play freely and to do just what they wanted. It was emphasized that no goal had to be achieved and that there was no “good” or “bad” behavior in the game.

Awareness of measurement. It makes a difference whether participants know that they are observed or not. Unaware participants are supposed to behave more authentically and unbiased. However, even if participants are aware of generally being observed, they sometimes do not know what exactly is in the focus of the research. Hence, they lack the specific awareness of the measurement procedure. While the general awareness of being observed certainly was present in Simoland, different game indices supposedly differ in becoming specifically aware. The participants probably know that certain choices of behavior are recorded, but we would argue that most participants are unaware if spacial distances to other Simos or viewing times are measured.

Controllability of behavior. Even if participants are aware that and how they are observed, and show a conscious or unconscious effort for impression management, that effort would only be consequential if the behavior in question can be under voluntary control. While self-reports and questionnaires are nearly arbitrarily manipulable, reaction times and even more physiological reactions are supposedly less prone to manipulation. But even if some behaviors could be perfectly controlled in under according instructions, humans usually do not do it all the time. There are several moderating factors that influence the actual amount of behavioral control (e.g. self awareness or cognitive load, Strack & Deutsch, 2004). In Simoland, most - if not all - measured behavioral indices can be controlled if participants are instructed about how they work and how they should control their behavior.

Consequences of behavior. Many studies in social psychology investigate human behavior using vignettes of situations with a subsequent forced choice of several possible behaviors. One weakness of this widespread procedure of investigating self-reported hypothetical behavior is the lack of social consequences (Furr, 2009). In Simoland, at least

some social consequences are present. For example, if the spouse is unduly criticized, he or she reacts angry, goes away, and is not in the mood for intimate interactions for some time. In a pretest of Simoland we asked participants about their experiences in the game and whether they experienced particular emotions. The majority of participants did so, and their answers in postexperimental interviews suggest a considerable impact of social consequences in the virtual world on them (e.g., “When my partner showed deeper feelings to the newcomer, it really shocked me. But I tried to convince him that I am the best for him!”).

To summarize, in virtual social environments like Simoland a variety of behavioral measures can be assessed. While the choice of behavioral options is more explicit, some other indices like spatial distances, time partitioning or viewing times are more implicit. While VSEs may not be as implicit as projective tests or pure reaction time measures, they certainly differ from self-declarative measures such as questionnaires.

Implementation of “Simoland”

In the implementation of Simoland we wanted to achieve an easy access for participants by keeping technical hurdles as low as possible. We therefore decided to implement a two-dimensional game using the Adobe Flash technology (version 9). With that approach every participant can play the game using an Internet browser, the only requirement being an installed Flash Player plugin (which applies to over 98% of internet users in Europe and the US, Adobe Systems Inc., 2009). The player’s character, the virtual spouse, as well as the other characters in Simoland were displayed as rather simple organisms (see Figure 1). As argued above, visual realism is not a necessary prerequisite for a successful immersion, and keeping it visually simple also ensures an easy and flawless distribution of the game over the Internet. Moreover, theoretical reasons speak in favor of a rather symbolic approach. The theory of the ‘uncanny valley’ (Mori, 1982) suggests that believability rises with increasing realism. In some region short of 100% realism, however, users are jolted by some minor inconsistencies, which completely destroy the illusion of realism. We would argue that in the case of close relationships, this poses a particular problem because the detailed knowledge of the significant other (e.g., facial features) alerts participants to visual inconsistencies prevents successful immersion.

In a pretest of the current study, we indeed found such a pattern. Participants were equipped with an elaborated editor for modeling a rather realistic face of a person. Participants were instructed to model an avatar of their real-life partner, which would be

used in the subsequent computer game. They could adjust the hair-do, hair and skin color, the shape and position of mouth, nose, eyes, etc. The pretest, however, was quickly aborted because the participants expressed enduring concerns about the accurateness of the virtual avatar of their partner and often ruminated about details of the avatar that completely prevented immersion in the game. While in several scenarios increased realism indeed might have an impact on believability and immersion (e.g. Yee, Bailenson, & Rickertsen, 2007), theoretical considerations and the experiences from our pretest led us to the conclusion that in the special case of a virtual spouse, “less is more”. We think that a symbolic depiction of the virtual partner decreases feelings of estrangeness and inconsistency, and rather provides a projection surface where behavioral and emotional characteristics of the real partner can be applied on.

Initially, the player’s character was alone in Simoland, providing the possibility to explore interactions with inanimate objects (e.g., eating cakes, drinking water, or listening to an MP3 player) and to learn to control the game. After a few minutes, the player’s virtual spouse and later some other inhabitants of Simoland (“Simos”) were introduced. Our aim was to construct a VSE that is easily applicable to a wide range of testing situations, and as automated and controllable as possible. Because this approach rules out confederates controlling the other characters in the environment, they are implemented as autonomous agents.

Whenever the participant clicked on an object, a menu of possible actions appeared, depending on the kind of object. When clicking on another Simo, more than 30 different actions appeared (see Table 1). The autonomous agents reacted according to an underlying model that takes several internal states into account, such as familiarity, the mood of the character, or the type of the last interaction. Generally speaking, the agents followed a tit-for-tat strategy. For illustration, we want to report a typical stream of interactions, which actually took place in the record of a male participant in the current study: The player approaches the spouse; he asks her to kiss him intensely; she refuses to do so; the player is pulling her legs; the spouse turns away, displaying mild anger; after 2 min., the participant approaches the spouse again, making a compliment; the spouse reacts delighted; the participant asks for a small kiss; the spouse kisses him.

The game was kept as visual as possible (see Figure 1) with all reactions depicted by symbols, colors (e.g. a red glow and grey steam for angry Simos), or movements (e.g. turning

away for disapproval). The only textual elements were some instructions and the labeling of the options one could choose.

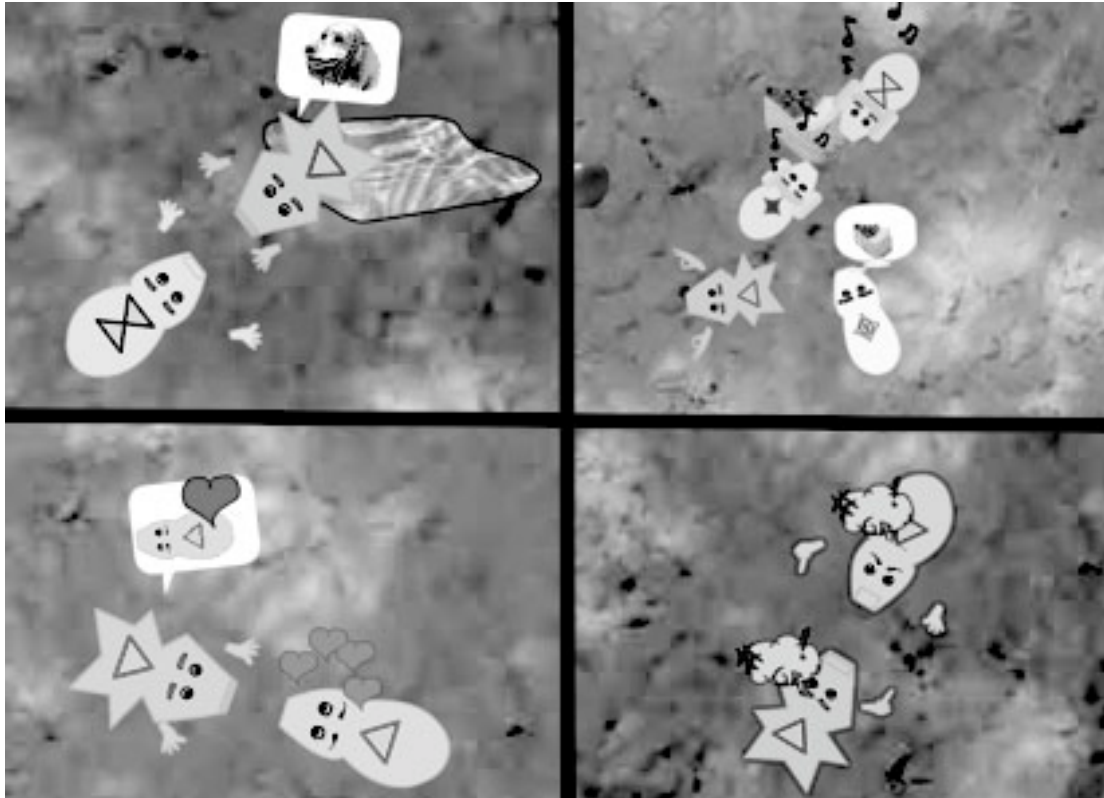

Figure 1: Four exemplary scenes from Simoland. The angular shaped character with the triangle on its back is the agent controlled by the participant. All other characters are autonomous agents. From top left to bottom right: (a) talking about hobbies, (b) a gathering of Simos engaged in different activities, (c) “I love you”, (d) a dispute.

Driving Forces of Behavior in Simoland

A key principle of psychological assessment is “The best predictor of future behavior is past behavior”. Accordingly, can we assume that “virtual behavior” is a valid predictor of “real behavior”? Some skeptics might state that behavior in computer games is completely arbitrary, or even that humans show the outright opposite reaction to what they would do in real life in order to safely experiment with other options. In contrast, however, many authors propose that participants’ virtual behavior is correlated with real life motives, attitudes, and behavioral tendencies, as behavioral scripts, schemes, or internal working models about social interactions supposedly guide both real and fictitious interactions (Blascovich et al., 2002; Fincham & Beach, 1988; Waters & Waters, 2006). What are some of the forces that drive behavior in the current implementation of Simoland?

Interpersonal Motives. As motives are defined as concerns that drive, orient, and select behavior (McClelland, 1987), we expect motives to play a key role in the selection and energization of virtual behavior as well. Concerning motives in the interpersonal domain, many authors propose two broad categories, which are described as “Communion-Agency”, “Love-Power”, or “Affiliation-Dominance” (e.g. Horowitz, Wilson, Turan, Zolotsev, Constantino, & Henderson, 2006). If these broad categories are applied to the case of romantic relationships, they can be termed as partner-related intimacy motive on the one hand, and partner-related autonomy motive on the other hand (Hagemeyer & Neyer, 2009; Hmel & Pincus, 2002; McAdams, Hoffman, Mansfield, & Day, 1996). The partner-related intimacy motive describes the need for closeness to a romantic partner, which is indicated by, e.g., frequent self-disclosure.

Concerning the other dimension, unfortunately different psychological constructs share the same label “autonomy” (Hmel et al, 2002). In our study, autonomy is conceptualized as “reactive autonomy” (Koestner & Losier, 1996). In this sense, highly autonomous individuals try to re-establish their independence if they experience a restriction of their freedom, or pressure from others. Hence, the need for autonomy in close relationships describes individuals who have a preference for experiencing individuality and independence from their partner, which, however, is not necessarily the opposite of experiencing intimacy. Therefore we conceptualize both motives as referring to orthogonal dimensions of interpersonal needs and behaviors. We expect that these motives play a key role in virtual relationship scenarios.

Presence. People differ on how strongly they get immersed into virtual realities and computer games, an experience called *presence* (Sanchez-Vives & Slater, 2005). This “sense of being there” could moderate the relationship between real world properties and in-game behavior. On the one hand, some authors (e.g., Blascovich et al., 2002) argue that a higher amount of presence increases the realism of virtual behavior, which could lead to a *more* valid assessment of interindividual differences. On the other hand, a stronger feeling of “being there” could also foster efforts for impression management and deliberative processing, which in turn could lead to a more uniform, socially accepted behavior and a *less* valid assessment of interindividual differences.

Iterative Choices. One advantage of VSEs is the possibility of assessing behavioral choices in an ongoing relationship. The relational choices that we make in our relationships do not exist in isolation, but rather are embedded both in a history of past choices and experiences, and a future that is influenced by the choices made at the very moment. The

focus on hypothetical “one-shot” situations, without any consequences for the real or imagined relationship, leads many studies to neglect this context. Furthermore, research on the prisoner’s dilemma shows that choice behavior is entirely different between one shot situations and iterative games where one has to interact repeatedly with the same partner (Axelrod, 1984; Vicary & Fraley, 2007). Vicary and Fraley (2007) already explored the evolution of relational choices in an imagined story with an ongoing relationship. While reading a short story about a relationship, participants encountered 20 choice points where they either had to choose a relationship enhancing alternative or a destructive alternative about how the story should continue. In three studies Vicary and Fraley (2007) analyzed the evolving choices within each participant, and found that the participants’ attachment style had an influence on both the start of the imagined relationship and on the course of choices they took during the evolving story.

The Current Study

We chose to implement a similar design to Vicary and Fraley (2007) that, however, differed in three respects. First, our story is presented visually rather than verbally, as visual stimuli supposedly have a more direct access to implicit motives and intuitive reactions (Schultheiss, 2001). Second, no forced choices at defined points are required; instead, the participants can interact with their virtual spouse whenever they want and how often they want, providing a more naturalistic setting and facilitating spontaneous behavior. Third, behavioral choices are not restricted to a dichotomous choice; in fact more than 30 different actions are possible. Implementing a tit-for-tat strategy, the spouse always reacts accordingly to the player.

Based on the above considerations, we developed several specific hypotheses regarding the interplay of game behavior and real life variables. Concerning intimacy, numerous studies have shown that certain verbal and non-verbal behaviors (e.g., emotional self-disclosure, gentle touching, physical proximity) are triggered by the intimacy motive and in turn create a feeling of intimacy (for an overview, see Prager, 1995). The respective behaviors in Simoland are categorized under the label “positive behaviors” (see Table 1). As intimate interactions usually occur within already familiar relationships (Prager, 1995), we only expect these behaviors to occur towards the virtual spouse, which – at least concerning his or her formal status – has a higher familiarity than the other unknown Simos in the game. Hence, we propose the following hypothesis at the level of aggregated behavior:

H1a: Participants with a higher intimacy motive show more positive behavior and less negative behavior to their virtual spouse, whereas their behavior to other Simos is unrelated to this variable.

Likewise, relationship satisfaction is a predictor for positive behavior in a relationship (e.g., Gottman & Levenson, 1992). As the virtual spouse is not introduced as an avatar of the real life partner, it may not be obvious that a good relationship satisfaction to the real life partner should predict behavior towards the so far unknown virtual spouse. Research on attachment, however, shows that experiences and mental representations from significant others are transferred from past relationships to new relationships, and also from past relationships to hypothetical relationships (Brumbaugh & Fraley, 2006; Roisman, Collins, Sroufe, & Egeland, 2005). Furthermore, research on the phenomenon of *transference* repeatedly has shown that relationships to significant others influence how interactions with new people unfold (Andersen & Cole, 1990; Andersen & Thorpe, 2009). This effect of transference, however, only takes place if the new person resembles the significant other in some minimal way. As physical features cannot account for this resemblance in the current setting (due to the symbolic depiction of the Simos), we expect that the mere relational status of the virtual spouse (“These two Simos have a romantic relationship”, see also below) suffices to trigger mental representations of the real life partner. In extending these findings from attachment theory and transference to the virtual setting, we propose the following hypothesis at the level of aggregated behavior:

H1b: Participants with a higher relationship satisfaction show more positive behavior and less negative behavior to their virtual spouse, whereas their behavior to other Simos is unrelated to this variable.

The current implementation of Simoland is a very unrestricted setting, where participants can do what they want, without any pressure or external control from the instructions, the other Simos, or the virtual spouse. As in the current scenario no triggers for reactive autonomy (Koestner et al., 1996) are present, the autonomy motive is not supposed to be relevant for virtual behavior in Simoland. Hence, we hypothesized that:

H2: Participants' autonomy motive is unrelated to their behavior toward the virtual spouse or other Simos.

Concerning the course of interactions we expect a differentiated effect for the start and the course of the virtual relationship. According to the theories and research on transference, we expect the virtual character to be a sort of “projection screen”, onto which expectations and behavioral patterns with the current real world partner are projected. Hence we propose that:

H3: Relationship satisfaction to the real world partner sets the initial level (i.e. the intercept) of interaction positivity.

During the course of interactions, however, motivational dynamics are supposed to shape behavior. *Persistence* as a key construct of motivational psychology describes the tendency to continue a behavior when no external pressures or requirements are present, even in the presence of obstacles or the absence of direct rewards (McClelland, 1987). This leads to our last hypothesis regarding the course of interactions:

H4: Participants high in intimacy motivation show a high persistence of close and positive behavior, and therefore show no decline of positive interactions over time, whereas participants low in intimacy motivation show a decline of positive interactions due to their lacking persistence.

As no directional hypothesis could be derived from existing literature concerning the impact of presence, we additionally explored the moderating effect of presence on the effects expected by hypotheses H1-H4.

Method

Participants

Participants were recruited to participate in an online experiment advertised on the online portal of the Department of Psychology, Humboldt-University Berlin (www.psytests.de). The announcement of the study required participants to be at least 18 years old and to be currently involved in a serious, heterosexual relationship with a relationship duration of at least six months. After removal of participants who did not meet these requirements, 236 participants remained in the final data set. The average age was 32 years ($SD=11$; range 18-66 years), 189 participants were female. As an incentive for participation, participants received a personality profile based on their individual responses directly after the experiment.

Procedure

The study lasted for about 35 minutes and consisted of three parts. At the beginning, a priming procedure was presented to the participants. They either had to visualize a moment in their relationship in which they felt very close to their partner (intimacy prime), or they had to visualize a moment where they wanted to be alone (autonomy prime). However, as this priming procedure did not show statistical effects on any of the analyses below, it is ignored in the remainder of this article.

As second part of the study, the game took place. Participants were guided through a short tutorial (about 3-6 min.) on how to play the game. The tutorial introduced the setting of the game as “Simoland” which is inhabited by several “Simos”. After these general informations, the player-controlled character (which was matched to the participant's sex) was introduced and it was shown how to control the player's character and how to start various interactions with inanimate objects and other Simos. Subsequently, the spouse of the player's character was introduced with the words: “These two Simos have a romantic relationship”. Concerning the relationship between the participant's agent and its virtual spouse, we intentionally kept the instructions as short as possible. The idea of the game is to assess spontaneous and operant (McClelland et al., 1989) reactions. Hence, we tried to activate the conscious self-concept as little as possible. Throughout the game, it never was stated that the Simo represents the participant; instead, it was only pointed out that commands can be given to one of the Simos. Likewise, we did not state that the virtual spouse represents the real-life partner of the participant. Furthermore, in order to increase spontaneous relationship behavior, we did not give any instructions about how the participant should behave (e.g., we did not tell participants that they should treat the virtual spouse the way they would treat their real-life partner). Additionally, we instructed participants to play freely and that no goals are to be achieved. To increase the social significance of their actions, however, it was pointed out that every choice they made had an effect on the mood and the behavior of the other Simos and would affect their relationship. After the tutorial, the game itself started and lasted for about 14 minutes.

Third, the following questionnaires were assessed, among others:

Closeness-Independence-Affiliation (CIA) Inventory (Asendorpf, Neberich, & Hagemeyer, 2010). We only assessed the Closeness and the Independence subscales of this inventory. These short scales were designed to assess the motive for closeness to a romantic partner (intimacy motive), as well as the motive for independence and being alone (autonomy motive), on a 7-point Likert scale ranging from 1 = *never* to 7 = *always*. In

previous studies these 8-item scales showed a good internal consistency (Cronbach's $\alpha > 0.88$).

Relationship satisfaction. As previous research indicates that single items can provide a pure and valid measure of relationship satisfaction (Doss, Rhoades, Stanley, & Markman, 2009), we assessed relationship satisfaction to the real world partner with the following single item on a 11-point Likert scale ranging from 0 = *very unsatisfied* to 10 = *very satisfied*: “How satisfied are you all in all with your current relationship?”

Presence. After the game, participants were asked to rate their feeling of presence on four items with a 5-point Likert scale ranging from 1 = *not at all* to 5 = *very strong*. Items have been adopted from existing presence questionnaires (Van Baren & Ijsselsteijn, 2004) to fit to Simoland (e.g. “How strong was your sense of “being there” in the game”, or “How aware were you of the real world surroundings while playing the game”; a full list of items can be obtained from the first author).

Statistical Procedure

Comparable to previous research in couple interactions (e.g. Gottman et al., 1992), all possible behavioral choices were *a priori* categorized into positive, neutral, and negative actions (see Table 1). We then calculated three game indices from aggregated behavioral choices towards the spouse: the ratio of positive choices to all choices (*positivity*), the ratio of negative choices to all choices (*negativity*), and the interaction frequency to the spouse divided by all interactions with other inhabitants of Simoland (*spouse-directedness*). Thus, all indices were standardized relative to the overall number of actions of each participant. Likewise, we calculated the positivity and the negativity index for interactions to all other Simos in the game.

Relationships between these game indices and personal characteristics of the participants were investigated with bivariate correlations. After transforming skewed variables by taking the inverse, logarithm, or square root, all but one variables still showed a significant deviation from normality (p values of the Shapiro-Wilk tests were $< .05$). As Pearson correlations of the transformed variables yielded virtually the same results as Spearman's rho, we decided to use this more robust measure of correlation.

Table 1: Possible Interactions in Simoland

<p>Positive behaviors</p> <p>talk about one's mood, talk about a joint future, talk about the relationship, kiss (in three variants: short kiss, romantic kiss, familiar kiss), "tell me how you feel", hear music jointly, dance together, make a compliment, say "I love you!", caress, smooch, tell a vision: having a family, lifelong love, meeting a soulmate</p>
<p>Neutral behaviors</p> <p>talk about hobbies, talk about occupational successes, gossip about other people, to turn sb. on (by showing off), call sb. to come, tell a vision: climbing a big mountain, being rich and successful, doing a world trip (alone)</p>
<p>Negative behaviors</p> <p>"go away – I want to be for myself", send away (angry), start an argument, criticize, insult, ridicule, annoy</p>

For the analysis of the course of interactions with the virtual spouse we were interested in the changes in the probability of a positive (vs. negative) choice during the course of the game. Therefore all actions towards the spouse were *a priori* coded as positive (= 1) or negative (= 0). Each interaction had a time stamp serving as a predictor to assess a linear trend over time. As the number of interactions varied between participants, and the occurrences were not equally distributed in time, a multi-level modeling strategy was applied. Employing a hierarchical model, personal characteristics were used as level-2 predictors that explained random effects both in intercept and slope of the linear regression of each participant's interactions on time (level-1). As the interactions were represented as binary responses, they were analyzed using a generalized linear mixed model with a logit link function (Gelman & Hill, 2007). The computational package lme4 (Bates, Maechler, & Dai, 2009) in the *R Environment for Statistical Computing* (R Development Core Team, 2008) was employed to fit the model.

To summarize, dependent variable was the valence of each interaction (positive or negative), level-1 regression predictor was the time stamp of each interaction, normalized with regard to the duration of the game (0 = start of the game, 1 = end of the game). Participants were treated as random factors. Predictors on level-2 were the intimacy and the autonomy score as well as relationship satisfaction. Or, to put it in other words, we estimated a logistic regression for each participant to see whether there was a linear trend in time to

show more or less positive interactions (level-1). Interindividual differences in the intercept (“How positive do they start?”) and the slope (“Is there a decline or increase in positivity?”) of this regression in turn are modeled by personality characteristics at level-2 (In generalized linear multilevel models, however, both steps are jointly estimated using a restricted maximum likelihood approach.).

In multilevel longitudinal models, it is usually assumed that the level-1 residuals are uncorrelated. In longitudinal models, however, one can often find an autoregressive structure among the residuals (Luhmann & Eid, 2009; Rovine & Walls, 2006) such that previous values of the dependent variable influence the current value. Hence, we controlled for a lag-1 autoregression by including an autoregressive parameter in our model so that the valence of a behavioral choice at time t_2 was predicted by the last choice at t_1 . The autoregressive parameter was centered on the individual level.

Results

Aggregated Behavior

Participants initiated 28.32 interactions with their spouse on average ($SD = 10.09$). From all non-neutral interactions, only 7% were classified as negative, a finding consistent with Vicary and Fraley (2007) where many decision points showed negative choice rates below 10%. Internal consistency of aggregated behavior was assessed by time-slicing the behavioral protocol into six equal slices and calculating the odd-even reliability for each game index (slicing into 4 or 12 slices yielded comparable results). The index *positivity* had an internal consistency of 0.18, *negativity* 0.66, and *spouse-directedness* 0.37. However, as argued above, behavioral choices in an ongoing relationship are not independent observations. As the recorded behaviors violate the assumption of local item independence, the calculated odd-even reliability should not be necessarily seen as a property of the assessment method but rather as a statement about the stability of the underlying behavior in the context of the presented situations. Furthermore, investigations of the properties of Picture Story Exercises (like the TAT) show that a low internal consistency often is not an upper ceiling for validity (as assumed by classical test theory), but rather that low internal consistency can be accompanied by high validity (e.g., Schultheiss, Liening, & Schad, 2008).

To investigate the relation between in-game behavior and real world variables we correlated these game indices with the personality scales and relationship satisfaction. All test scores showed internal consistencies (Cronbach's α) $> .73$, see Table 2. As the game

indices showed a highly skewed distribution we used Spearman's ρ as an index of correlation. All behavioral indices towards the spouse significantly correlated with two of the assessed personality variables (see Table 2): Participants high in intimacy motivation and with a high relationship satisfaction showed more interactions with the virtual spouse overall, more positive interactions, and fewer negative interactions. The autonomy motive yielded no significant correlations, as predicted.

Concerning the behavior to other Simos, only two coefficients were significant: Participants with a higher spouse-directedness showed a lower ratio of positive (but not more negative) behaviors towards other Simos. Furthermore, participants with a higher relationship satisfaction with their real life partner showed a lower ratio of positive interactions to others. Hence, the relationship-related variables like intimacy motive and relationship satisfaction only correlated with spouse-directed behavior in the expected direction.

To test whether the regression with spouse-directed behavior continued to be significant if other-directed behavior was taken into account, we ran additional multiple regression analyses where the spouse-directed behavior was controlled for the other-directed behavior. In these analyses, the results were virtually identical with the results without controls.

Course of Interactions

For the investigation of the time course of behavioral choices, we analyzed intraindividual changes of positive vs. negative choices over time. Unit of analyses were 3042 observable positive or negative behaviors nested in the interactional records of 236 participants. Therefore each participant's change in behavior was assessed with 13 data points on average, allowing an assessment of intraindividual change based on many assessments. Since the dependent variable was the binary outcome of a positive (vs. negative) interaction with the virtual spouse, the intercept in the model refers to the probability of a positive interaction at the beginning of the game, while the slope refers to a linear trend of a declining or increasing probability of a positive interaction during the course of the game (logistic curve). The best model fit was achieved by allowing both intercepts and slopes of the level-1 predictor to vary across participants. In the model, intercept variance was 6.71 and slope variance was 11.42. Compared to the unconditional model, level-2 predictors explained 11% of the variance both in intercepts and slopes. In the following we concentrate on the fixed effects of the model (see Table 3).

Table 2: Spearman Correlations between Game Indices and Personality Variables

Measure	1	2	3	4	5	6	7	8
1. Positivity (spouse)	-							
2. Negativity (spouse)	-.30***	-						
3. Spouse-directedness	.06	-.19**	-					
4. Positivity (others)	-.02	.02	-.23***	-				
5. Negativity (others)	.04	.10	.09	-.21**	-			
6. Presence	-.11	.08	.11	-.05	.03	.73		
7. Intimacy motive	.15*	-.29**	.22***	-.05	-.02	.04	.81	
8. Autonomy motive	-.08	.05	-.04	-.08	.02	.11	-.35***	.82
9. relationship satisfaction (real life partner)	.15*	-.20**	.16*	-.14*	.05	.00	.42***	-.13*

Note. Values in the diagonal are Cronbach's α (where applicable).

* $p < .05$. ** $p < .01$. *** $p < .001$.

Table 3: Generalized Linear Multilevel Model of Interaction Positivity: Fixed Effects

Predictor	Estimate (<i>logits</i>)	<i>SD</i>	<i>p</i>
Intercept	4.10	0.33	<.001
Intercept x autoregression	0.54	0.20	.008
Intercept x relationship satisfaction	0.72	0.34	.034
Intercept x intimacy motive	-0.33	0.37	.369
Intercept x autonomy motive	-0.18	0.35	.609
Intercept x presence	0.34	0.33	.294
Time	-0.97	0.46	.034
Time x relationship satisfaction	-0.82	0.49	.093
Time x intimacy motive	1.19	0.52	.023
Time x autonomy motive	0.22	0.49	.658
Time x presence	-0.34	0.46	.460

The significant effect of relationship satisfaction on the intercept shows that participants who were satisfied with their real world relationship started the game with more positive behaviors. In contrast, the time trend of behavior was only affected by the intimacy score; participants with a higher intimacy motive tended to keep or slightly increase their positivity, while a low intimacy motive led to a decrease in positivity (see Figure 2).

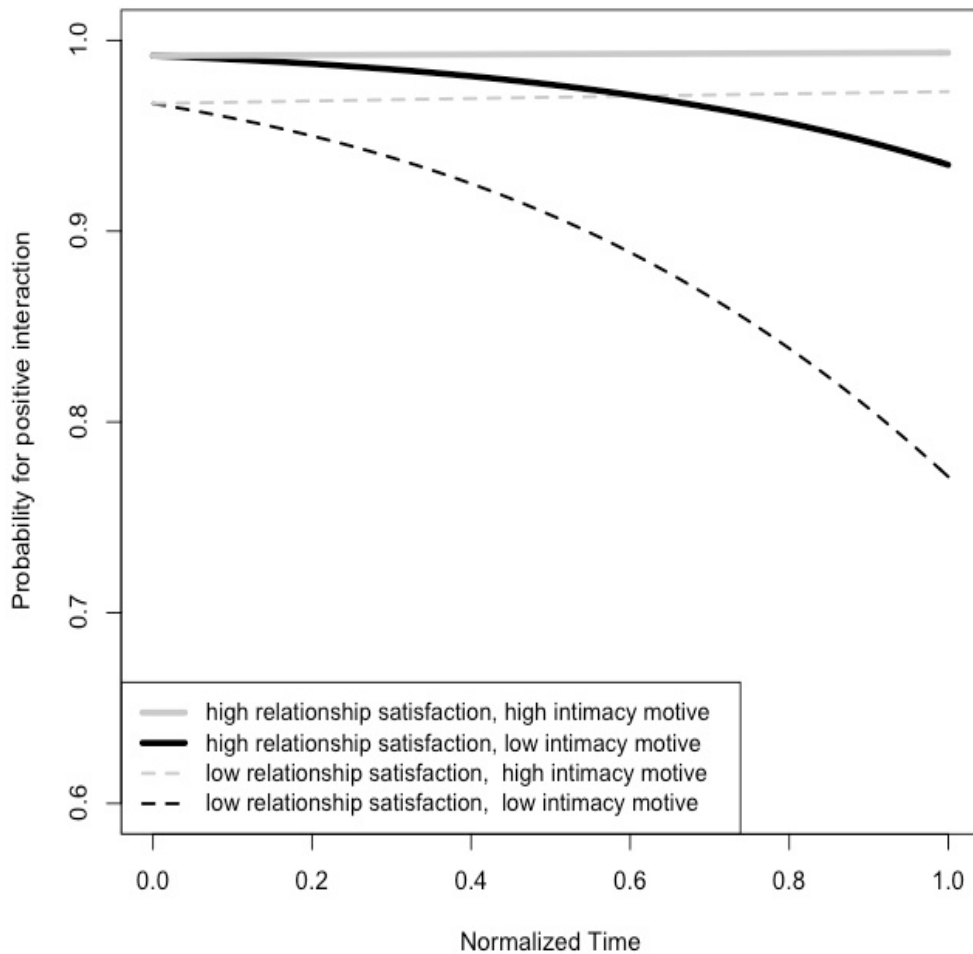

Figure 2: Logistic slopes of the final GLMM. Logits are transformed to probabilities to ease interpretation. Logistic curves are plotted at ± 1 SD of intimacy motive and relationship satisfaction. Other predictors are set to zero (i.e. to the sample mean), except the autoregression parameter, which was set to the individual mean.

Concerning autoregression, a significantly positive coefficient was estimated. Hence, there is some behavioral stability in the stream of behavior, as the positivity of the current behavior matches the last behavior with a probability greater than zero¹.

1. We also tested a lag-2 and a lag-3 autoregression. These parameters, however, neither were significant, nor did their inclusion change the coefficients of the other predictors.

Moderating Effect of Presence

For testing the possible moderating effect of presence on bivariate correlations we conducted hierarchical multiple regressions with products of the standardized predictors as interaction terms (Aiken & West, 1991). The interaction terms with the presence score did never reach significance, indicating that felt presence does not moderate the relationship between personality variables and aggregated game indices².

Concerning the course of interactions, we added a main effect for presence, as well as interaction terms between presence and all other level-2 predictors into the model. Neither the main effect for presence nor the interaction terms including presence reached significance (see Table 3). Therefore the amount of felt presence did not moderate the course of interactions in general, nor the between-participant effects.

Discussion

The aim of the current article was to demonstrate the potential of virtual social environments for psychological assessment with the actual implementation “Simoland”. We investigated the relationship between the behavior towards a virtual spouse and real-life variables (i.e., interpersonal motives and relationship satisfaction). We tested four hypotheses on aggregated behavior, the initial state and the dynamics of virtual spouse interactions, and found support for all of them, providing one of the first evidence that behavior in virtual social environments is not completely arbitrary but is correlated with “real life”. To clarify, we do not assume that participants think that the virtual spouse represents the real partner, but rather that stable emotional and behavioral schemes (i.e., the interpersonal motives), as well as expectations from the current relationship are transferred to the virtual spouse.

In our study, participants treated the virtual spouse according to their personality and their experiences in the current real life relationship. Our results suggest that participants transfer their experiences and expectations from their real relationship into the virtual world. Participants who are less satisfied with their real relationship start less positive into the virtual relationship, perhaps re-instantiating their current mode of relationship in the virtual environment. During the game, however, the behavior of the participants gets more and more shaped by their intimacy motive: Only participants high in intimacy motivation

2. Concerning non-normality, we ran moderation analyses both with untransformed variables and with the best possible transformation applied to the skewed variables. The interaction terms stayed insignificant, regardless of transformation.

continue to show and even increase the ratio of positive and close interactions. This reflects the effect of behavioral persistence in highly motivated persons (McClelland, 1987). Furthermore, these results could only be found concerning spouse-directed behavior – behavior to other Simos does not show these patterns. This finding adds to the validity of Simoland, as indeed partner specific behavioral tendencies are expressed (and not a general tendency towards all virtual agents). The only significant (but low) correlation between real world variables and other-directed behavior was an unexpected increase of positive behavior towards others in participants with a low real life relationship satisfaction. A possible interpretation of this result could be that participants with a dissatisfying real life relationship project their negative expectations on the virtual spouse, and rather try to establish close and positive interactions with other Simos.

The analysis of the process of interactions highlights another strength of the approach: While the intimacy motive and relationship satisfaction showed comparable correlational patterns concerning aggregated behavior, both could be dissociated in the process analysis of behavior. Although both constructs showed a substantial correlation at the aggregate level ($r = .42$), the analysis of interactions revealed that both are not the same. While relationship satisfaction sets an initial bias for interactions, motivational dynamics unfold over time, supporting the usefulness of time-course analyses for the investigation of motivational and interactional processes. Due to the unrestricted nature of the setting, we hypothesized that participants with a high need of autonomy had no need of breaking free from any restrictions (i.e., there was no instigating situation for the autonomy motive to get active). As predicted, the autonomy motive did not have an influence on behavior in this study. One of the reviewers, however, pointed to an alternative explanation for this null result: it could be that participants with a high autonomy motivation expressed their autonomy by breaking off from the study, which would have caused a restriction of variance. We assessed the autonomy motive after the game, hence we cannot test for a selective drop out. While we cannot rule out this alternative explanation, we would argue that participants had no need to break off from the study, as the nature of the setting was more unrestricted than in most other psychological studies. Furthermore, participants could have easily expressed their autonomy within the game, by not interacting with the spouse, keeping the distance, or engaging in flirting or conversation with others.

The analysis of the moderating role of presence showed no differences between participants with high and low presence. Therefore, if VSEs are to be employed as diagnostic tools in the future, we provided preliminary evidence that their validity does not seem to be

affected by the attitude of how participants approach and experience the game. Furthermore, these findings are the first to demonstrate the effect of transference towards a virtual relationship. This effect might be employed to develop new assessment methods that operate on a projective level, where unconscious internal working models and mental representations are applied on a virtual agent.

An increasing number of papers in psychology emphasize the importance of observing actual behavior in contrast to hypothetical choices or self-reported intentions (e.g., Baumeister, Vohs, & Funder, 2007; Furr, 2009). Furthermore, other researchers have a strong distrust in self-report measures and argue that the observation of interactional processes is the key for understanding relationship outcomes (Gottman, 1998). Virtual environments can be useful tools for the generation and observation of actual behavior. One major obstacle, however, is the immense effort of setting up the virtual environments. Although we chose to implement a rather simple two-dimensional game, it took a long time to get it run smoothly. However, data analysis was relatively simple, as we did not have to go through hours of video coding, which means a shift in efforts from data coding to the preparation of the study. As another advantage, coding of behavior is unambiguous and straightforward, as all relevant behaviors have been classified *a priori* and one has not to deal with problems like interobserver reliability drift or decay (Gottman, 1998). Now that Simoland has been implemented it is relatively simple to construct new scenarios and experimental variations³. Furthermore, the computer game has not necessarily to be built up from scratch like we did. Depending on the research question, existing computer games with scripting ability could be employed (Frey, Hartig, Ketzler, Zinkernagel, & Moosbrugger, 2007).

Limitations of the study

Both the theoretical considerations as well as the study itself have some limitations. Concerning empirical data of the current study, a considerable limitation is the uneven ratio of gender. With 80% female participants it is questionable whether results also generalize to a broader underlying population. Due to the low power resulting from the small sample size of men, separate correlational analyses of both genders are not very expedient. Adding gender as another level-2 predictor to the multilevel model of interactions, however, neither

3. Researchers interested in using Simoland for their own research are encouraged to contact the first author.

resulted in a significant coefficient nor did it alter the other coefficients, which provides at least preliminary evidence that the results are valid for both genders.

In the introduction, we argued that VSEs have the potential to measure psychological properties on a rather implicit level. A potential limitation of the the current study design is the reliance on self-report measures as validating criteria. Hence, it is hard to assess whether the game indices indeed have implicit properties. While the introduction tried to focus on general ideas and properties of open virtual social environments (VSEs), the degrees of freedom in the construction of such environments are so numerous that it might be inappropriate to subsume different implementations under a common label. One has to take a close look on each single implementation of a VSE (e.g. which scenarios are presented? Are specific goals present for the participant or is it a rather free exploration of the world? Are certain motives activated or not? How is the behavior of other characters in the game modeled?). Furthermore, although we argue that virtual behavior is actual behavior, these records of virtual behavior lack many indices of nonverbal and uncontrollable behavior investigated in other studies (like tenseness of the body posture; e.g. Asendorpf, Banse, & Mücke, 2002). Therefore virtual environments will never replace observational studies in the lab or in the field, but rather complement them. The advantages of virtual environments become apparent in testing situations that rule out or complicate a lab setting, like embarrassing interpersonal situations with sexual content, unethical experimental manipulations, like arranging an extramarital affair for the partner, or the testing of participants who are living far apart, cannot move (e.g., prisoners), or have rare characteristics such that they are scattered across the country. The playful character of the game also could make it suitable for studying children's reactions in social situations.

Future Studies

In the current study, we did not construct a specific scenario but rather provided an open environment to be freely explored by the participants. We investigated the basic properties of VSEs - future studies should progress by addressing theory-driven hypotheses and by modeling specific situations like the induction of conflicts, or attachment related separation scenes. Additionally, one could model specific reaction styles from the virtual spouse. Furthermore, future studies should incorporate other measures that broaden the scope of correlates of virtual behavior: real-life-outcomes, behavioral observations in laboratory setting, diary data, or implicit measures like an IAT. In any way, we believe that

the use of virtual social environments and computer games is a promising and viable way for the study of social interactions beyond self-report.

References

- Adobe Systems Inc. (2009). *Adobe Flash Player version penetration*. Retrieved Aug 24, 2009, http://www.adobe.com/products/player_census/flashplayer/version_penetration.html
- Aiken, L. S., & West, S. G. (1991). *Multiple regression: Testing and interpreting interactions*. Thousand Oaks, CA: Sage Publications.
- Andersen, S., & Cole, S. (1990). "Do I know you?": The role of significant others in general social perception. *Journal of Personality and Social Psychology*, 59, 384-399.
- Andersen, S. M., & Thorpe, J. S. (2009). An IF-THEN theory of personality: Significant others and the relational self. *Journal of Research in Personality*, 43, 163-170.
- Asendorpf, J. B., Banse, R., & Mücke, D. (2002). Double dissociation between implicit and explicit personality self-concept: The case of shy behavior. *Journal of Personality and Social Psychology*, 83, 380-393.
- Asendorpf, J. B., Neberich, W., & Hagemeyer, B. (2010). *Closeness-Independence-Affiliation (CIA) Inventory*. Unpublished scales. Humboldt University, Berlin, Germany.
- Axelrod, R. (1984). *The evolution of cooperation*. New York: Basic Books.
- Bates, D., Maechler, M., & Dai, B. (2009). lme4: Linear mixed-effects models using S4 classes (R package version 0.999375-32) [Computer software].
- Baumeister, R. F., Vohs, K. D., & Funder, D. C. (2007). Psychology as the science of self-reports and finger movements: Whatever happened to actual behavior. *Perspectives on Psychological Science*, 2, 396-403.
- Blascovich, J., Loomis, J., Beall, A. C., Swinth, K. R., Hoyt, C. L., & Bailenson, J. N. (2002). Immersive virtual environment technology as a methodological tool for social psychology. *Psychological Inquiry*, 13, 103-124.
- Brumbaugh, C., & Fraley, R. (2006). Transference and attachment: How do attachment patterns get carried forward from one relationship to the next? *Personality and Social Psychology Bulletin*, 32, 552-560.
- De Houwer, J., Teige-Mocigemba, S., Spruyt, A., & Moors, A. (2009). Implicit measures: A normative analysis and review. *Psychological Bulletin*, 135, 347-368.
- Doss, B. D., Rhoades, G. K., Stanley, S. M., & Markman, H. J. (2009). The effect of the transition to parenthood on relationship quality: An 8-year prospective study. *Journal of Personality and Social Psychology*, 96, 601-619.
- Fazio, R. H., & Olson, M. A. (2003). Implicit measures in social cognition research: Their meaning and uses. *Annual Review of Psychology*, 54, 297-327.
- Fincham, F. D., & Beach, S. R. H. (1988). Attribution processes in distressed and nondistressed couples: 5. Real versus hypothetical events. *Cognitive Therapy and Research*, 12, 505-514.
- Frey, A., Blunk, H. A., & Banse, R. (2006). Psi-Land: Paarinteraktionsforschung in einer virtuellen Umgebung [Psi-Land: Investigating interactive behaviour in romantic couples in a virtual environment.]. *Zeitschrift für Sozialpsychologie*, 37, 151-159.

- Frey, A., Hartig, J., Ketzel, A., Zinkernagel, A., & Moosbrugger, H. (2007). The use of virtual environments based on a modification of the computer game Quake III Arena (R) in psychological experimenting. *Computers in Human Behavior, 23*, 2026-2039.
- Furr, R. M. (2009). Personality psychology as a truly behavioural science. *European Journal of Personality, 23*, 369-401.
- Gelman, A., & Hill, J. (2007). *Data analysis using regression and multilevel/hierarchical models*. New York: Cambridge University Press.
- Gottman, J. M. (1998). Psychology and the study of marital processes. *Annual Review of Psychology, 49*, 169-197.
- Gottman, J. M., & Levenson, R. W. (1992). Marital processes predictive of later dissolution: Behavior, physiology, and health. *Journal of Personality and Social Psychology, 63*, 221-233.
- Greenwald, A. G., & Banaji, M. R. (1995). Implicit social cognition: Attitudes, self-esteem, and stereotypes. *Psychological Review, 102*, 4-27.
- Greenwald, A. G., McGhee, D. E., & Schwartz, J. L. K. (1998). Measuring individual differences in implicit cognition: The Implicit Association Test. *Journal of Personality and Social Psychology, 74*, 1464-1480.
- Hagemeyer, B., & Neyer, F. (2009). *The Operant Motive Test for partner relationships (OMT_P): A new implicit measure of the partner-related needs for intimacy and autonomy*. Manuscript submitted for publication.
- Hmel, B. A., & Pincus, A. L. (2002). The meaning of autonomy: On and beyond the interpersonal circumplex. *Journal of Personality, 70*, 277-310.
- Horowitz, L. M., Wilson, K. R., Turan, B., Zolotsev, P., Constantino, M. J., & Henderson, L. (2006). How interpersonal motives clarify the meaning of interpersonal behavior: A revised circumplex model. *Personality and Social Psychology Review, 10*, 67-86.
- Koestner, R., & Losier, G. F. (1996). Distinguishing reactive versus reflective autonomy. *Journal of Personality, 64*, 465-494.
- Luhmann, M., & Eid, M. (2009). Does it really feel the same? Changes in life satisfaction following repeated life events. *Journal of Personality and Social Psychology, 97*, 363-381.
- McAdams, D. P., Hoffman, B. J., Mansfield, E. D., & Day, R. (1996). Themes of agency and communion in significant autobiographical scenes. *Journal of Personality, 64*, 339-377.
- McCall, C., Blascovich, J., Young, A., & Persky, S. (2009). Proxemic behaviors as predictors of aggression towards Black (but not White) males in an immersive virtual environment. *Social Influence, 4*, 138-154.
- McClelland, D. C., Koestner, R., & Weinberger, J. (1989). How do self-attributed and implicit motives differ? *Psychological Review, 96*, 690-702.
- McClelland, D. C. (1987). *Human motivation*. New York: Cambridge University Press.
- Mori, M. (1982). *The Buddha in the robot*. Charles E. Tuttle Co.
- Prager, K. J. (1995). *The psychology of intimacy*. New York: Guilford Press.
- R Development Core Team. (2008). *R: A Language and Environment for Statistical Computing*. Vienna, Austria: Basic Books.

- Roisman, G., Collins, A., Sroufe, A., & Egeland, B. (2005). Predictors of young adults' representations of and behavior in their current romantic relationship: Prospective tests of the prototype hypothesis. *Attachment & Human Development, 7*, 105-121.
- Rovine, M. J., & Walls, T. A. (2006). A multilevel autoregressive model to describe interindividual differences in the stability of a process. In T. A. Walls & J. L. Schafer (Eds.), *Models for intensive longitudinal data* (pp. 124-147). New York: Oxford University Press.
- Sanchez-Vives, M. V., & Slater, M. (2005). From presence to consciousness through virtual reality. *Nature Reviews Neuroscience, 6*, 332-339.
- Schultheiss, O. C. (2001). An information processing account of implicit motive arousal. In M. L. Maehr & P. Pintrich (Eds.), *Advances in motivation and achievement (Vol. 12: New directions in measures and methods)* (pp. 1-41). Greenwich, CT: JAI Press.
- Schultheiss, O. C., Liening, S. H., & Schad, D. (2008). The reliability of a Picture Story Exercise measure of implicit motives: Estimates of internal consistency, retest reliability, and ipsative stability. *Journal of Research in Personality, 42*, 1560-1571.
- Strack, F., & Deutsch, R. (2004). Reflective and impulsive determinants of social behavior. *Personality and Social Psychology Review, 8*, 220-247.
- Tichon, J., & Banks, J. (2006). Virtual reality exposure therapy: 150-Degree screen to desktop PC. *CyberPsychology & Behavior, 9*, 480-488.
- Van Baren, J., & Ijsselstein, W. (2004). Measuring presence: A guide to current measurement approaches. OmniPres project IST-2001-39737. Retrieved Feb 28 2007, from <http://www.presence-research.org/omnipres/D5.pdf>
- Vicary, A. M., & Fraley, R. C. (2007). Choose your own adventure: Attachment dynamics in a simulated relationship. *Personality and Social Psychology Bulletin, 33*, 1279-1291.
- Waters, H. S., & Waters, E. (2006). The attachment working models concept: Among other things, we build script-like representations of secure base experiences. *Attachment and Human Development, 8*, 185-197.
- Yee, N., Bailenson, J., & Rickertsen, K. (2007). A meta-analysis of the impact of the inclusion and realism of human-like faces on user experiences in interfaces. *Proceedings of the SIGCHI conference on Human factors in computing systems*, 1-10.

Chapter 4

Transference of adult attachment dynamics to a virtual spouse

Felix D. Schönbrodt and Jens B. Asendorpf

Humboldt University Berlin, Germany

The study investigated the effect of transference of attachment working models onto autonomous agents in a virtual social environment. Participants encountered three attachment-related key scenes (separation, conflict, threat) which were embedded in an online computer game. In this game, participants had control over the main character (the "protagonist") who had a virtual romantic relationship to one of the other agents. Recorded were numerous behaviors, which participants instructed the protagonist to do (positive vs. negative behaviors, physical distance, support seeking), as well as emotions participants ascribed to the protagonist. Based on recent research investigating actual behavior in comparable real life situations, we made several predictions about how participants should control the protagonist in our virtual environment. In most cases, participants' attachment styles correlated as predicted with the way they instructed the protagonist to behave towards the virtual spouse. This study opens new ways to investigate attachment-related behavior by using virtual environments that allow experimental variations of the virtual partner's reactions and other situational variables.

Introduction

Transference describes the phenomenon that representations of significant others influence our perception of unknown persons, as well as emotional and motivational responses towards them (Andersen & Cole, 1990; Andersen & Thorpe, 2009). In a similar fashion, attachment theory (Bowlby, 1980) assumes that representations of early childhood experiences and other past relationships shape an internal working model that influences new relationships. The current study builds on this notion of transference by investigating whether transference occurs when people immerse themselves into online games designed to include virtual attachment-related situations, and whether their working models of attachment can thus be used to characterize their behavior in these games.

Transference

Transference is a well documented phenomenon. For example, Andersen and colleagues found that features of unknown target persons are inferred from features of a significant other, and that evaluations of the target are influenced by transference, both in explicit evaluations and in presumably uncontrolled facial expressions (for an overview, see Andersen & Thorpe, 2009). Transference effects also influence expectancies for acceptance or rejection in a new relationship, triggers specific interpersonal behavior of the participants (Berk & Andersen, 2000), and activates specific motivations and goals (Berk & Andersen, 2008). In a similar fashion, attachment theory emphasizes the idea of transferring attachment-related mental representations acquired in past relationships to new relationships (Ainsworth, Blehar, Waters, & Wall, 1978; Bowlby, 1980; Fraley, 2007; for a discussion of the connection between transference and attachment theory, see Saribay & Andersen, 2007). In a study of interpersonal perceptions in small groups, for example, Mallinckrodt and Chen (2004) could show that memories of parents' attachment behaviors correlated with biases in interpersonal perception in a meaningful way (e.g., participants with recollections of an overprotective mother tended to see other group members significantly less friendly-submissive). In two studies with faked profiles of online communities, of which some resembled a prior romantic partner or a parent, Brumbaugh and Fraley (2006, 2007) found that both global and relationship specific working models are transferred to these hypothetical persons.

In most studies, targets of transference have been short verbal descriptions of hypothetical persons (see, however, Berk & Andersen, 2000). These verbal descriptions allow

a high degree of controllability, and they presumably maximize the perceiver variance as no distracting unique features of the target person are present. However, attachment researchers themselves theorize that the attachment system primarily gets active in situations of distress or threat, and that interindividual differences in attachment style are most pronounced in such situations (Hazan, Campa, & Gur-Yaish, 2006; Simpson & Rholes, 1998; Simpson, Rholes, & Phillips, 1996). Hence, these vignettes might lack the social realism and situational features that are potentially necessary to trigger the attachment system (Furr, 2009; Shaver & Mikulincer, 2006).

A New Approach to Transference: Attachment-related Situations in Virtual Social Environments

We propose a new approach to studying attachment dynamics based on transference: Both a virtual actor that is controlled by the participant and an autonomous agent who serves as an attachment figure are used as targets of transference processes in a virtual social environment (VSE), in which typical attachment-related situations are created. Virtual environments are advocated as promising tools in psychological research, providing a unique combination of both mundane realism and experimental control (Blascovich et al., 2002; Schönbrodt & Asendorpf, in press). In a VSE where interaction partners are modeled as autonomous agents, the investigation of close relationships has several distinct features in contrast to conventional methods like self-report measures, laboratory studies, or interviews. First, the researcher has full experimental control over the actions and reactions of the virtual interaction partners. Second, special scenarios can be created that are hard or impossible to present in the laboratory with real persons (e.g. the death of a parent, or the infidelity of the romantic partner). Third, in contrast to vignettes, behavioral dynamics over time can be investigated (Schönbrodt & Asendorpf, in press). Fourth, in contrast to vignettes, interpersonal situations in VSEs are anchored in the experiential system (McClelland, Koestner, & Weinberger, 1989; Schultheiss, 2001). For example, situation-contingent facial expressions of the agents, background music, or triggered events can be used to increase the feeling of immersion of the participant and to elicit spontaneous and automatic reactions. Fifth, both data collection and data analyses can be more easily accomplished: Testing can be done over the internet, and due to automatic coding, reliable behavioral indices can be obtained without the effort of coding hours of video material.

Although some researchers already investigated social behavior in virtual environments (e.g., Frey, Blunk, & Banse, 2006; McCall, Blascovich, Young, & Persky, 2009),

to our knowledge no such study has been conducted to investigate adult attachment or the effect of transference.

Concerning the virtual attachment figure, if the aim is to investigate internal working models of a person through transference, it is desirable to reduce uncontrolled variance of the target. Thus, the ideal figure would be a blank slate onto which a general working model can be projected, or a figure characterized only by a most general description (e.g., mother, spouse). The same applies to the actor in the VSE that is controlled by the participant.

It has been shown that representations of significant others have a high and chronic baseline of accessibility, even in the absence of any individuating cues of the target (Andersen & Thorpe, 2009). Hence, we argue for the use of a rather symbolic and de-individualized representation of the targets of transference in VSEs. While in some research settings more realistic virtual agents might enhance believability and the validity of psychological effects (e.g., Yee, Bailenson, & Rickertsen, 2007), we argue that in our scenario it is just the indeterminism of the virtual spouse which enhances the mechanism of transference and the application of internal working models (for a more detailed discussion, see Schönbrodt & Asendorpf, in press). This symbolic depiction does not necessarily constrain the interaction with virtual characters, as it has been shown that humans are capable of processing symbolic representations of persons in almost the same manner as real persons (Sanchez-Vives & Slater, 2005; see also the classic study by Heider & Simmel, 1944). In addition, research shows that as simple manipulations as single threat words like "separation", or subliminal priming of attachment figures are sufficient to activate the attachment system and to make attachment figures symbolically available (Mikulincer, Gillath, & Shaver, 2002; Mikulincer & Shaver, 2007).

Concerning the actor that is controlled by the participant, we assume that the participant transfers own emotions and behavioral tendencies to this main character in the VSE, although the main character is not explicitly introduced as a representation of the participant¹. However, as it performs all actions under the command of the participant, we

1. Support for this approach also can be drawn from a completely different research tradition, namely the assessment of implicit motives by means of picture story exercises (Schultheiss & Pang, 2007) like the Thematic Apperception Test (TAT). Stories written to these pictures usually are written about other persons from a third person's view; nonetheless valid inferences about the implicit motives of the writer can be drawn. In some coding systems, stories written from the first person's perspective even are discarded (Waters & Waters, 2006).

assume that participants put themselves into the actor's position, feel with it, transfer their own current emotions to it, and let it perform behaviors as a proxy person for them.

The Virtual Social Environment Simoland

According to these principles, we developed a VSE called “Simoland” which was presented as an online computer game² (Schönbrodt & Asendorpf, in press). Simoland was “inhabited” by several autonomous agents called *Simos*. In the story of the computer game, the main character whose gender was matched to that of the participant had a romantic relationship to another Simo. For clarity of description, we introduce here some labels that will be used throughout this paper: The participant-controlled Simo will be called the *protagonist*, its romantic partner will be called the *virtual spouse* or just *spouse*, and all other Simos will be called *the other Simos*. While all Simos were autonomous agents which interacted with each other and their environment (e.g., they searched for food, started conversations amongst each other, listened to music, etc.), participants could control the protagonist. Whenever the participant clicked on an object or another Simo, a list with possible actions appeared which the protagonist could perform with that object. Over 30 actions were available, and included for example: kissing, talking about hobbies, tell how you feel, flirting, dance together, etc. (for a complete list of possible actions see Schönbrodt and Asendorpf, in press). All other Simos (including the virtual spouse) were autonomous agents which interacted with each other and their environment. Generally, the autonomous agents reacted according to a tit-for-tat strategy (for details on the underlying model of the agents see Schönbrodt and Asendorpf, 2010, in press). Concerning the virtual spouse, we did not use characteristics of the real-life partners to increase resemblance, as explained above. Instead, we used symbolic representations (see Fig. 1).

2. Researchers interested in using Simoland for their own research are encouraged to contact the first author.

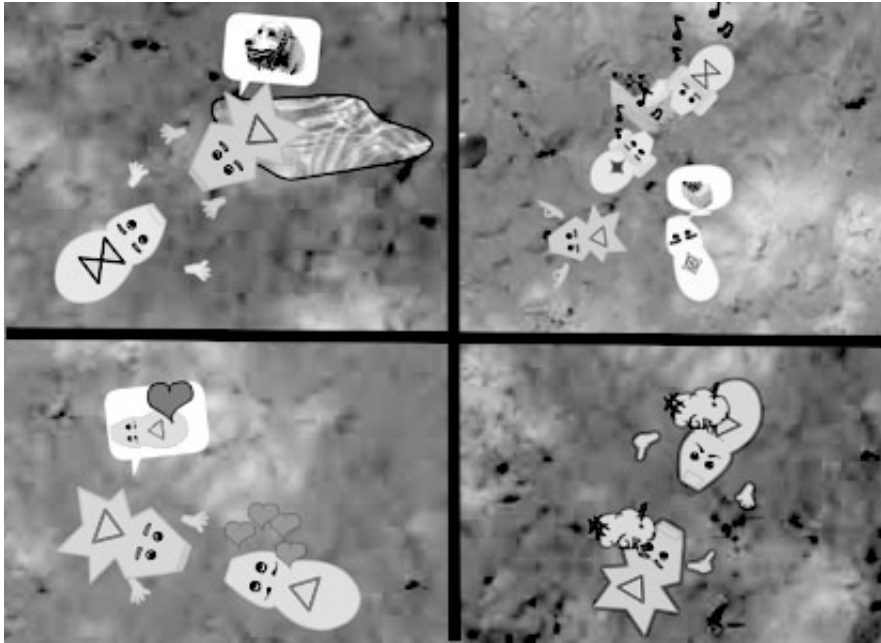

Figure 1: Four exemplary scenes from Simoland. The angular shaped character with the triangle on its back is the agent controlled by the participant. All other characters are autonomous agents. From top left to bottom right: (a) talking about hobbies, (b) a gathering of Simos engaged in different activities, (c) “I love you”, (d) a dispute. Adapted from Schönbrodt and Asendorpf (in press, Fig. 1).

During the game, participants encountered different scenes. Whereas the first part was identical for all participants, in the middle of the game, a key scene occurred: Each participant encountered one of three attachment-related scenes (a separation scene, a conflict with the spouse, or a threat for the protagonist) which allowed studying participants reactions on these events (for details on the scenes, see the Methods section below).

In order to increase readability of the following sections, we do not speak of the “participant's behavior”, but rather of the “protagonist's behavior” – although its behavior of course is directed and initiated by the participant. Concerning emotions, we did not ask the participant for a self-report of own emotions, but rather asked “How does the protagonist feel at the moment?”. Hence, we consequently speak of *ascribed emotions* when we refer to these emotion ratings.

The Present Study

Based on the VSE framework explained above, the current study investigates attachment-related behavior towards a virtual spouse in Simoland. More specifically, we investigated whether the attachment style of the participant, varying on the dimensions

attachment Avoidance and attachment Anxiety³, can predict how participants control a protagonist's behavior towards the virtual spouse. In the current study, three different attachment-relevant situations are systematically varied between participants: a separation scene (the virtual partner has to leave for an indefinite amount of time), a conflict scene (the virtual partner wrongly accuses the protagonist of infidelity), and a threat scene (the protagonist learns to know that he or she maybe has a deadly disease). We derived three types of indices from game behavior: behavioral indices (which actions were chosen?), the physical distance between the protagonist and the virtual spouse, and emotion ascriptions. For the sequence of scenes see Figure 2.

All three scenarios pose an attachment-related danger to the protagonist. The danger, however, has a different nature in each setting. In the separation scene, the attachment figure is currently not available, but the attachment bond is not generally challenged. In the conflict scene, the attachment figure physically is available, but the bond might be challenged due to the conflict. In the threat scene, the attachment figure is available, and the threat is from outside the relationship. Hence, in the last scenario, the bond is not challenged, and the attachment figure is theoretically available to be used as a safe haven.

Hypotheses

Based on existing literature on these attachment related key scenes, we developed specific hypotheses concerning the impact of attachment styles onto the protagonist's behavior in each scenario. If no specific hypotheses could be derived, we proposed hypotheses based on general assumptions about secondary attachment strategies (Mikulincer & Shaver, 2005; Mikulincer, Shaver, & Pereg, 2003; Shaver & Mikulincer, 2002): Anxious individuals are supposed to engage in *hyperactivating* strategies, which encompass constant vigilance and effort until an attachment figure is perceived to be available, a strong approach orientation toward relationship partners, attempts to elicit their support, as well as efforts aimed at minimizing the distance from them. Avoidant individuals, in contrast, engage in *deactivating* strategies, which keep the attachment system deactivated so as to avoid frustration. These strategies encompass the denial of attachment needs, avoidance of closeness and dependence in close relationships, as well as efforts to maximize the emotional and physical distance.

3. To avoid confusions, we write Avoidance and Anxiety in upper case letters when we refer to the dimensions of attachment styles. When referring to the common sense of both words, they are written in lower case.

We furthermore explored the interaction between Anxiety and Avoidance scores. As in most previous studies this interaction turned out to be insignificant (see, however, Dewitte, Koster, De Houwer, & Buysse, 2007), we did not expect systematic interaction effects.

Baseline situation. Participants in all conditions encountered a common part at the beginning of the game where only the protagonist and the virtual spouse were present. While one purpose of this scene was to let the participant get acquainted with the game, we also could explore the behavior towards the spouse in an unstructured situation unrelated to attachment. If projective identification with the protagonist occurs, the current emotions of the participants (assessed before the start of the game) should be projected onto the protagonist. As the key scene in the middle of the game is supposed to change the emotions of the protagonist, the correlations to the initial state of participants' emotions should decrease over the course of the game, particularly from the key scene onwards.

Hypothesis 1: Correlations between participants' current emotions and the ascribed emotions of the protagonist (a) are significant at the beginning of the game and (b) get lower particularly from the key scene onwards.

Separation. Many researchers think that distress due to separation and loss is one of the strongest indicators of an attachment bond (Bowlby, 1980). The earliest test of attachment styles, the strange situation procedure (Ainsworth et al., 1978), is based exactly on this fact. In a study on attachment styles and separation behaviors, Fraley and Shaver (1998) observed separating and non-separating couples in a naturalistic study at an airport. Concerning attachment styles, avoidant separating women showed less proximity seeking behaviors and more withdrawal behaviors (e.g., pulling away, or not making eye contact). Anxiety did not predict behavior in women, but their self reported distress.

There are, however, two key differences between this study and the classic strange situation procedure. First, in this study behaviors to an anticipated separation are assessed, whereas in the strange situation the separation is not announced. Second, due to the special setting of airport separations it was not possible to observe the behavior during the reunion episode. This inevitable restriction is unfortunate, as in the original work of the strange situation it was argued that it is the reunion episode which has a high diagnostic value (Ainsworth et al., 1978).

In a recent study, Diamond, Hicks, and Otter-Henderson (2008) investigated the full sequence of preseparation, separation, and reunion in a diary study of couples who experienced temporary physical separations (for an overview on couple separations also see

Vormbrock, 1993). In their study they differentiated between the homebound partner and the traveling partner. As in our scenario the spouse leaves the protagonist, we focus on Diamond et al.'s results for the actor effects of the homebound partner. Amongst many other results, they found for all participants a significant decline in positive affect from the pre-separation to the separation episode, as well as a significant recovery from separation to reunion. Furthermore, homebound avoidant participants initiated less remote contacts.

In our study, we assessed behavior both during the separation and the reunion episode. In contrast to both studies cited above, the separation was not announced, as in the original strange situation procedure. According to the presented findings, and based on attachment theory's general predictions, we propose that:

Hypothesis 2: Participants ascribe (a) a decline of positive emotions to the protagonist during separation, and (b) an increase of positive emotions during reunion.

Concerning attachment *Avoidance*, we propose the following hypotheses:

Hypothesis 3: During the Separation scene, individuals high in Avoidance control the protagonist such that it (a) keeps less contact to the absent spouse, and (b) does not show distress.

Hypothesis 4: During the Reunion scene, individuals high in Avoidance control the protagonist such that it actively avoids contact with the spouse. That means it (a) keeps a greater physical distance, (b) initiates less interactions in general and in particular (c) less positive interactions, and (d) does not feel emotionally relieved by the reunion.

Concerning attachment *Anxiety*, we propose the following hypotheses:

Hypothesis 5: During the Separation scene, individuals high in Anxiety control the protagonist such that it keeps the contact to the absent spouse by (a) thinking of the spouse and (b) writing letters to him or her; also, anxious participants (c) ascribe a decline of positive emotions to the protagonist.

Hypothesis 6: During the Reunion scene, individuals high in Anxiety control the protagonist such that it tries to reassure the bond by an increased frequency of interactions.

Conflict. In the Conflict condition, the spouse wrongly accuses the protagonist of infidelity. In their literature review of the connection between attachment styles and emotions in close relationships, Mikulincer and Shaver (2005) summarized reactions from anxious and avoidant people to negative behaviors of their partners. Amongst others, they reported the following results for individuals scoring high on attachment *Avoidance*: (a) they show a mixture of suppressed anger (i.e., they do not consciously report anger) and high levels of hostility (Mikulincer, 1998); (b) they use distancing strategies to the partner

(Mikulincer, 1998); (c) after a negative relational episode, they are less likely to forgive a partner who had hurt them, which is manifested in a strong desire for revenge as well as negative feelings (Mikulincer & Shaver, 2005).

Translated to Simoland, we propose the following hypotheses:

Hypothesis 7: Avoidant individuals control the protagonist such that it (a) does not show decreasing positive emotions during conflict, but instead expresses its hostility by exhibiting (b) more negative and (c) less positive behaviors.

Hypothesis 8: Avoidant individuals control the protagonist such that it uses distancing strategies during conflict by (a) keeping a greater physical distance and (b) initiating fewer interactions with the spouse.

Hypothesis 9: After the conflict, avoidant individuals control the protagonist such that it shows (a) more negative behaviors towards the spouse (desire for revenge), (b) less positive behaviors towards the spouse, and (c) no recovery of positive emotions.

Concerning individuals high in attachment *Anxiety*, predictions are less clear as these individuals are supposed to “react to a partner’s negative behaviors with a complex mixture of resentment, hostility, anger, self-criticism, fear, sadness, and depression” (Mikulincer & Shaver, 2005, p. 155). In a diary study about the perception of conflict, Campbell, Simpson, Boldry, and Kashy (2005) found that anxious individuals have a heightened sensitivity to conflict (i.e., they perceived more conflicts with more severity), and that they showed more self-reported distress during conflict (see also Simpson et al., 1996). As we did not ask about the participants’ perceptions of the conflict, but only assessed the current emotions of the protagonist, we propose only following hypothesis for individuals high in attachment Anxiety:

Hypothesis 10: Anxious individuals ascribe more feelings of distress to the protagonist during conflict.

Threat. In the threat condition, a doctor tells the protagonist that he or she presumably has a deadly disease (later in the game, it is revealed that it only was a false alarm). This scenario was designed to assess, whether the virtual spouse is used as a safe haven. For avoidant persons, under conditions of stress the attachment should be suppressed (deactivating strategy), and consequently less support seeking behavior should be shown (Mikulincer & Florian, 1998; Mikulincer & Shaver, 2005; Rholes, Simpson, & Oriña, 1999):

Hypothesis 11: In the Threat scene, individuals high in Avoidance control the protagonist such that it (a) initiates fewer interactions overall and (b) shows less support seeking behavior.

As the spouse is at some physical distance during the Threat scene, we do not expect an increased distance for avoidant individuals. During the Comfort scene, however, the spouse actively decreases the distance. Only in this situation, the deactivating system should be in charge:

Hypothesis 12: Participants' Avoidance is (a) unrelated to the physical distance between the protagonist and its virtual spouse in the Threat scene, and (b) positively related in the Comfort scene.

In a key study on the interplay between adult attachment and threatening conditions, Simpson, Rholes, and Nelligan (1992) investigated behavioral reactions of women who waited together with their partners for an anxiety-provoking situation. Against expectations, they found no relation between interindividual differences in attachment Anxiety and support seeking behavior. Hence, theoretical predictions and previous empirical results do not fully correspond. Anyway, we propose the following hypothesis derived from theory:

Hypothesis 13: During the Threat scene, individuals high in Anxiety control the protagonist such that it stays closer to the spouse and initiates more interactions overall.

Concerning Avoidance, Simpson et al. found an interaction between observer rated stress and Avoidance on the amount of observer rated comfort seeking: For securely attached persons, comfort seeking increased with increasing stress, while for avoidant persons comfort seeking *decreased* with increasing stress. In another study, however, this result could not be replicated for men (Simpson, Rholes, Oriña, & Grich, 2002). As previous results on support seeking are mixed, we did not formulate a directed hypothesis, but explored in the Threat scene, whether we could replicate the interaction found by Simpson et al. (1992).

Method

Participants

A community sample was recruited to participate in an online experiment advertised on the online portal of the Department of Psychology, Humboldt-University Berlin (www.psytests.de). The announcement of the study required participants to be at least 18 years old and to be currently involved in a serious, heterosexual relationship with a relationship duration of at least six months. After removal of participants who did not meet these requirements, 422 participants remained in the final data set (separation: 144, conflict: 131, threat: 147). The average age was 28.53 years ($SD = 9.67$; range 18 to 65 years), 353

participants were female. Average relationship duration was 4.82 years ($SD = 6.68$; range = 6 months to 42 years). As an incentive for participation, participants received a personality profile based on their individual responses directly after the experiment.

Procedure

Based on a literature research, we selected three scenes of a relationship that are relevant to adult attachment. The first part of the game was identical for each participant. After that common part, randomly one of the three key scenes was presented (see Figure 2). In the next sections all scenes are described; for the ease of description, the scenes are described from a male participant's point of view (i.e., the protagonist is male and the virtual spouse is female).

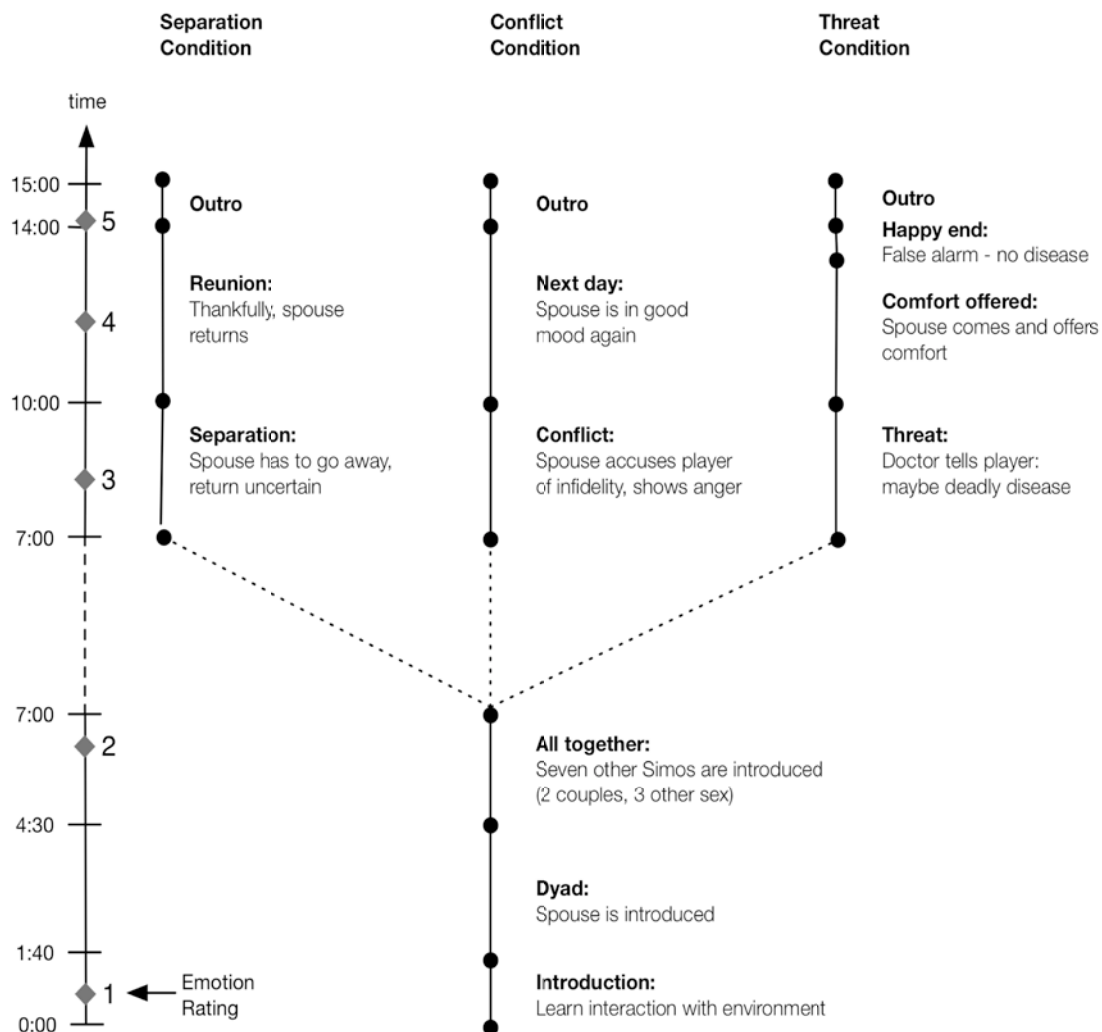

Figure 1: Sequence and timing of the three game scenarios

The common part: Introduction / Dyad / All-Together. The first 7 minutes of game play were identical for each participant. At the beginning of the game, the protagonist was alone in Simoland, giving the participant the opportunity to learn the handling of the game and to learn the interaction with inanimate objects (“Introduction”; in the following text, scene names are always referred to in uppercase names). Next, the virtual spouse was introduced. For the next three minutes, the couple was alone in Simoland (“Dyad”). Participants could freely choose to instruct their protagonists to interact or not with the spouse. As the last scene of the common part, several other Simos were introduced into the game (two other couples, and a peer group of three Simos, which had the opposite sex of the participant; “All together”). At the end of this scene, one of the following three key scenes was presented, depending on the experimental condition.

Separation. The rationale behind this scene was to induce a separation which was due to external factors (i.e., not a separation due to an unsatisfied relationship). At the beginning of this scenario a pre-scripted cut scene was shown (during cut scenes, participants could not give commands to the protagonist). The spouse approached the protagonist and told him that a near relative of her has died. She further told him that she had to go to a far-away town, which was a very dangerous journey, and that it was uncertain when she will return. Then, the spouse started to cry because of the separation. She walked away, but then returned, gave her partner a kiss, and then finally went away, still crying. The whole scene was accompanied by a very sad song (“Ne me quitte pas” from Jaques Brel), and at the end the screen was slowly faded out to black. After a couple of seconds, the screen faded in again (a new day began) and the protagonist was alone (the other Simos, however, still were present). For the following 3 minutes (“Separation”) the protagonist stayed alone, uncertain about the return of the spouse. After that period, night fell again. At the dawn of the next morning, a message was displayed that the spouse returned safely, and the camera was directed towards the spouse, who approached the protagonist from the edge of the game world (“Reunion”). From that moment on, no more scripted events took place and participants could freely instruct their protagonist to interact with the spouse or anybody else. Hence, the scene was an analogue of the strange situation procedure known from infant attachment research (Ainsworth et al., 1978).

Conflict. The rationale of this scene was to induce a conflict into the virtual relationship. As several pretests showed that it is rather difficult to evoke negative behaviors in Simoland, a rather strong manipulation was chosen: The spouse came to the protagonist and yelled at him that she heard gossip about him cheating her with another woman. The

spouse displayed very strong anger (see Figure 1), started to argue, and left. For the next three minutes, the spouse had a special behavioral scheme: She never initiated an interaction with the player's Simo, and for the next three interactions initiated by the participant, she reacted angry and rejected the protagonist (regardless the positivity of the protagonist's approach). After these three rejections the spouse returned to her former tit-for-tat behavior. This scene ("Conflict") lasted for three minutes. After that, it fell night in Simoland. At the next dawn, the spouse was internally reset to her normal mode of behavior ("Next day"). Hence, the conflict was not explicitly resolved, as the spouse only displayed no more anger and reciprocated positive behaviors from the protagonist.

Threat. The rationale of this scene was to induce a threat for the protagonist to see whether the spouse is used as a safe haven. In this scene ("Threat") a doctor was introduced with the words that the protagonist now has a routine checkup. The doctor delivered some bad news: the protagonist probably had a deadly disease. The diagnosis is not definite yet, but if he had the disease, he would have to die within 3 weeks. The doctor emphasized that the disease was not contagious at all (i.e., the protagonist could approach the virtual spouse without risking to infect her). The spouse, who did not know anything about the disease yet, stayed at the edge of the screen (i.e., she was generally accessible). At first, the spouse did not approach the protagonist actively, but she reacted positively if the participant initiated an interaction. After three minutes, the spouse actively approached the protagonist (regardless whether they interacted before) and offered comfort by saying "Should I comfort you?" ("Comfort"). One minute before the end of the game, the doctor delivered good news: It was a false diagnosis, the protagonist is not sick at all ("Happy End").

Outro. At the end of the game, in each condition a message appeared that in one minute the game would be over. Starting with this message, a slow fade out started (it went night in a rapid sundown), until the screen was black. After that, several questionnaires (see below) were assessed.

Emotion ascriptions during the game. At five predefined points the game was paused without prior announcement and a short questionnaire was displayed. We asked the participant which emotions the protagonist currently experiences (see Figure 2 for the timings of these ratings). The scales were chosen to reflect emotional reactions important to attachment related issues (sad - lonely; lonesome - safe/protected; angry - peaceful; anxious - confident; strained - relieved; disappointed - trustful; weak - strong). These emotion ratings were assessed with 7 bipolar Likert scales. The positive side of each scale was counter-balanced between left and right.

Current Emotions. Prior to the start of the game, we asked for participants' current emotions using the PANAVA-KS questionnaire (Schallberger, 2005). This questionnaire assesses current emotions on three scales: positive affect (4 items), negative affect (4 items), and valence (2 items). Given the brevity of the scales, internal consistencies were sufficient (Cronbach's $\alpha > .72$). For better comparability with our bipolar scales from the game, we calculated the difference score between positive affect and negative affect. All analyses were performed with this difference score.

Attachment Scales. To assess attachment styles, we employed a short version of the revised Experiences in Close Relationships questionnaire (ECR-R; Fraley, Waller, & Brennan, 2000). This questionnaire assesses generalized attachment Anxiety and Avoidance each with ten items on a 7-point Likert scale. Both scales showed a good internal consistency ($\alpha > .88$).

Demographic data. We assessed the relationship duration with the current partner, the age, and the gender of the participants.

Statistical Procedure

As data analytic strategy, we analyzed the common part of the game for the combined sample. After that, each scenario is reported in a separate section. During the game, three types of indices were measured: the interactional options participants selected, the physical distance between the protagonist and the spouse, and the emotion ascriptions.

Interactional choices. Comparable to previous research in couple interactions (e.g. Gottman & Levenson, 1992), all possible behaviors were a priori categorized into positive, neutral, and negative actions (for details of possible actions and categorizations, see Schönbrodt & Asendorpf, in press). We then calculated three game indices from aggregated behavioral choices towards the spouse: the ratio of positive actions to all actions (positivity), the ratio of negative actions to all actions (negativity), and the interaction frequency to the spouse divided by all interactions with inhabitants of Simoland (spouse-directedness). Thus, all indices were standardized relative to the overall number of actions of each participant.

The positivity index included 11 actions (e.g., kissing, talking about one's mood, talk about the relationship, ask how the other feels), and the negativity index included 7 actions (e.g., send the other away, criticize, insult, start an argument); further actions were categorized as neutral (e.g., talk about hobbies, talk about occupational successes, gossip about other people). For the threat condition, we calculated an additional behavioral index

called “support seeking”, which included following actions: tell your spouse how you feel at the moment, talk about the recent events, call the spouse, think of the spouse.

Physical distance. We furthermore calculated the mean physical distance between the protagonist and the virtual spouse for each scene. As the distribution of all distances was skewed to the right, all distances were transformed by a $1/x$ transformation. Single outliers with a z value > 3 were winsorized (i.e., their value was set to a raw value corresponding to the z value of 3; Wilcox, 2005), which further improved the normality of the distribution.

Emotion ascriptions. As the seven Likert scales of the in-game emotion ratings were highly homogenous (Cronbach’s α in each assessment $> .80$), they were combined to an average score. All further analyses were done with this average emotion rating. To test our hypotheses about intra-individual changes in the level of positive emotions, we added the emotion rating from the prior scene as control variable into the multiple regression models, referred to as “emotion baseline” (e.g., to test for the emotional drop down due to the separation, we predicted the emotional rating from the Separation scene while controlling for the base line rating from the prior scene All together). The difference from the scene All together to the key scene will be labeled “emotional drop down”, and the change from the key scene to the following scene will be labeled “emotional recovery”.

Using hierarchical multiple regressions, we regressed these game indices onto attachment Anxiety and Avoidance. To control for gender and the log-transformed relationship duration, these variables were entered in Block 1 (in the case of emotional drop down and recovery we also added the emotion ascription from the previous scene as additional control variable). Attachment Anxiety and Avoidance were entered as main effects in Block 2, and the size and significance of the incremental validity (ΔR^2) was evaluated. As ancillary analyses, we also entered the Anxiety X Avoidance interaction as Block 3. Due to the high number of models, we adjusted the level of significance to correct for Type I error inflation. After this correction, no interaction term remained significant.

Results

Descriptive statistics of all game indices, the attachment scales, and the current emotions are displayed in Table 1.

Table 1: Descriptive Statistics of Frequencies of Actions, Physical Distance, Emotional Ascriptions, Attachment Dimensions, and Participants' Emotions

Measurement	Separation		Conflict		Threat	
	<i>M</i>	<i>SD</i>	<i>M</i>	<i>SD</i>	<i>M</i>	<i>SD</i>
Game index						
Interactions overall	21.30 _{a,b}	8.37	23.05 _a	8.84	19.48 _b	7.15
Interactions with spouse	15.87 _a	5.77	18.47 _b	7.27	15.67 _a	5.84
% Positive actions to spouse	31.9% _a	0.11	37.3% _b	0.13	39.5% _b	0.12
% Negative actions to spouse	6.7%	0.04	7.2%	0.05	6.1%	0.03
% Spouse-directedness	76.7% _a	0.14	81.0% _b	0.13	81.1% _b	0.12
Support seeking actions	3.36 _a	2.10	3.58 _a	1.90	4.48 _b	2.63
Physical distance ^a	1.35 _a	0.51	1.56 _b	0.58	1.57 _b	0.60
Emotional ascription	3.95 _a	1.39	3.62 _b	1.55	3.59 _b	1.58
Participant related measures						
Anxiety	3.05	1.23	3.06	1.24	3.07	1.32
Avoidance	2.16	0.96	2.04	1.02	1.93	0.77
PANAVA: Emotional positivity ^b	0.81	1.81	0.73	1.98	0.88	1.92

Note. $n = 144$ (Separation), 131 (Conflict), 147 (Threat). Different subscripts indicate significant differences ($p < .05$).

^aDistances are $1/x$ transformed to correct for skewness.

^bThis difference score is calculated as positive affect – negative affect. Possible range of this difference score is from -6 to +6.

The Course of Emotions

The descriptive course of emotion ascriptions in all conditions is displayed in Figure 3. In all conditions, a major decline of positive emotions occurred in the key scene. Linear mixed effect models were used to test whether this decline was significant, and whether differences between conditions occur. For that, we calculated a planned contrast between the key scene and the four other scenes, as well as *post hoc* pairwise comparisons of the three conditions to assess potential differences between them. Participants were entered as random factor to control for differences in the initial state of emotion ascriptions.

The analysis revealed that the contrast between the key scene and the other scenes was highly significant ($F(1,1681) = 1928.66, p < .001$). Hence, the experimental manipulation effectively influenced participants' perception of the situations. The main effect of the experimental condition on emotion ratings also was significant ($F(2,418) = 13.74, p < .001$),

as was the interaction between the contrast and the experimental condition ($F(2, 1681) = 17.57, p < .001$).

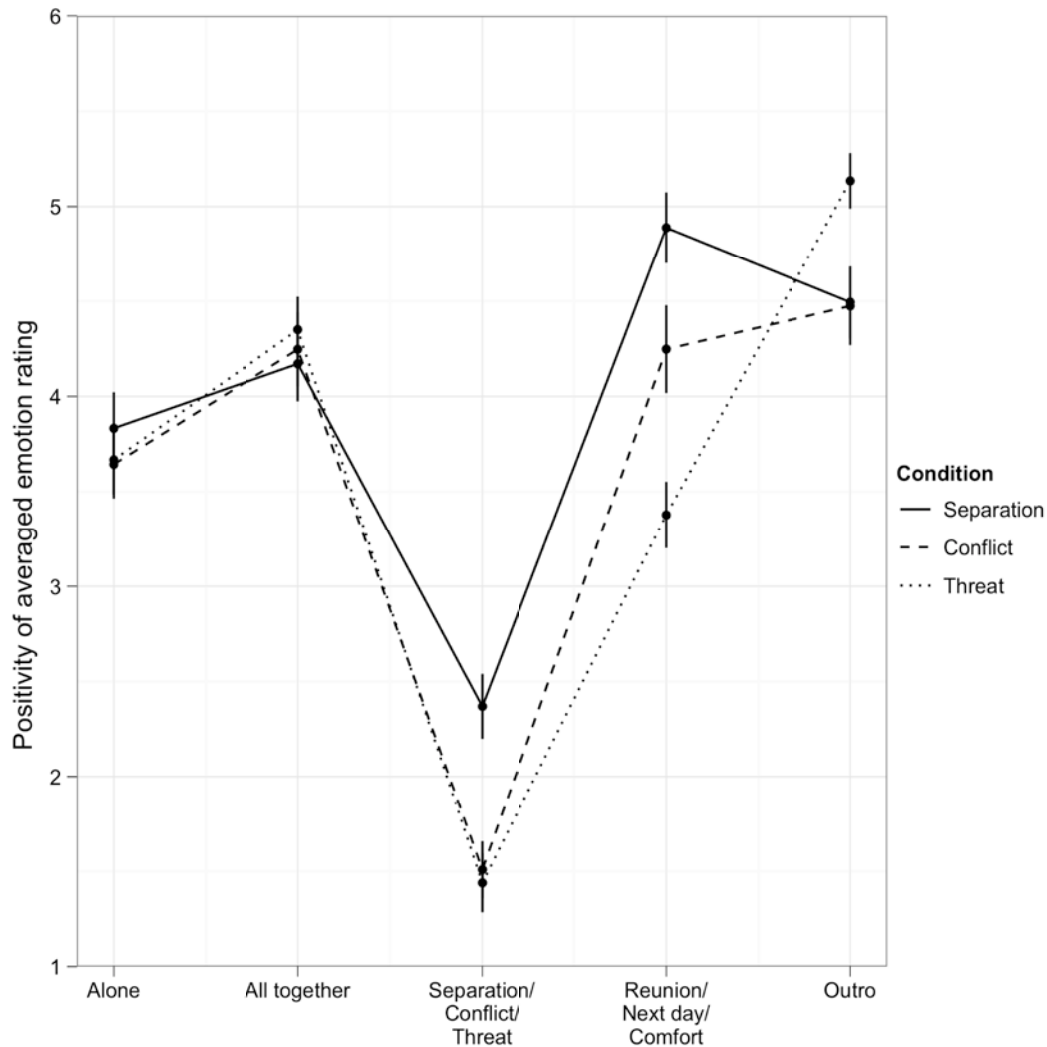

Figure 2: Mean course of emotion ascriptions to the protagonist in three different scenarios. Error bars represent the 95% confidence interval for the mean in each scene.

As can be inferred from Figure 3, pairwise comparisons between the three conditions showed that the decline in the Separation condition was significantly lower ($p < .001$) than in the other two conditions, which did not differ among each other ($p = .91$). An additional analysis revealed that the decline within the Separation condition was significant as well ($F(1,571) = 458.39, p < .001$), which supports Hypothesis 2.

Transference of Current Emotions to the Protagonist

We asked for the current emotions of participants immediately before the game took place. If transference of emotions to the protagonist appeared, these emotional ratings should correlate with the emotions ascribed to the protagonist. In fact, participants' emotions were transferred to the protagonist: Pearson correlations between the PANAVA difference score and the emotion ascriptions in the game scenes were $r = .30, .21, .12, .17,$ and $.17$ in the scenes Alone, All together, Separation/Conflict/Threat, Reunion/Next day/Comfort, and Outro, respectively ($n = 422$, all $ps < .05$). A test for comparing depending correlation coefficients (Meng, Rosenthal, & Rubin, 1992; Steiger, 1980) was employed to test whether these coefficients significantly differ. In fact, the overall test for differences was significant ($\chi^2(4) = 11.03, p = .026$). A planned contrast (2, 1, -1, -1, -1) that directly tested Hypothesis 1 was highly significant, too ($z = 3.04, p = .001$). Hence, we found full support for Hypothesis 1.

The Common Part

Table 2 reports the results of the multiple regressions. In the Dyad scene, avoidant participants commanded the protagonist to show less positive and more negative behaviors towards the spouse. When the other Simos were introduced, attachment styles did not predict any spouse directed behavior.

Table 2: *The Common Part (Dyad and All Together): Multiple Regression of Game Indices onto Attachment Anxiety and Avoidance*

Index	Block 1 relationship			Block 2		
	gender	duration	R^2	Anxiety	Avoidance	ΔR^2
<i>Scene: Dyad</i>						
Distance	.04	-.02	.00	-.01	.10 [†]	.01
Positivity	-.08	-.14**	.03**	-.02	-.10*	.01*
Negativity	.05	.07	.01	.01	.29***	.08***
<i>Scene: All together</i>						
Distance	.07	-.02	.01	.00	.09 [†]	.00
Spouse-directedness	-.04	.06	.00	.07	-.03	.01
Positivity	-.03	-.11*	.01 [†]	.03	-.04	.01
Negativity	.00	.12*	.01 [†]	.01	.00	.00

Note. Each row refers to standardized regression coefficients of the same hierarchical regression ($n = 422$). Relationship duration and physical distance are transformed (\log resp. $1/x$) to correct for skewness.

[†] $p < .10$. * $p < .05$. ** $p < .01$. *** $p < .001$.

Separation

Results from the multiple regression analyses are reported in Table 3. No face-to-face interaction with the spouse was possible during the Separation scene. Nonetheless, participants could instruct the protagonist to show two spouse related behaviors: a) Writing a letter to him or her. Out of 146 participants, 29 wrote a letter once, and two participants twice; b) Thinking of the spouse. Out of 146 participants, 63 thought once of the spouse, 12 twice, 6 three times, and 1 participant four times. As both variables were heavily skewed, for analyses we dichotomized the variable for protagonists who did (= 1) and did not write a letter (= 0), respectively did or did not think of the spouse.

Table 3: Separation Condition: Multiple Regression of Game Indices onto Attachment Anxiety and Avoidance

Index	Block 1				Block 2		
	Emotion base line	gender	relationship duration	R ²	Anxiety	Avoidance	ΔR ²
<i>Scene: Separation</i>							
Writing a letter		-.12	-.17*	.06*	-.01	-.07	.01
Thinking of the spouse		.10	.11	.02	.19*	-.13	.05*
Positive emotion during separation ^a	.11	.09	-.06	.03	-.26**	.09	.06*
<i>Scene: Reunion</i>							
Physical distance		.05	-.16 [†]	.03	-.05	.18*	.03 [†]
Spouse-directedness		.02	.11	.01	.15 [†]	-.20*	.06*
Positivity		-.02	-.07	.01	.07	-.25**	.06**
Negativity		-.02	.16 [†]	.03	.10	.04	.01
Positive emotion after reunion ^a	-.01	.00	.12	.02	-.06	-.32**	.10**

Note. Each row refers to standardized regression coefficients of the same hierarchical regression ($n = 144$). Relationship duration and physical distance are transformed (\log resp. $1/x$) to correct for skewness.

^a "Positive emotion" refers to emotions participants ascribed to the protagonist.

[†] $p < .10$. * $p < .05$. ** $p < .01$. *** $p < .001$.

During separation, the Avoidance score did not predict contact maintenance behavior; neither did avoidant participants ascribe a smaller emotional drop down to the protagonist. Hence, Hypothesis 3 could not be confirmed. During reunion, however, the protagonists of avoidant participants had a higher physical distance, initiated less interactions overall and less positive interactions in particular to the spouse. Furthermore, avoidant participants did not ascribe an emotional recovery to the protagonist. These findings fully support

Hypothesis 4 and demonstrate a replication of Ainsworth et al.'s classic description of avoidant behavior during the reunion phase.

Thinking of the spouse, but not writing a letter, correlated with Anxiety, which partially supports Hypothesis 5. Further support for this hypothesis could be found concerning emotion ascriptions: The higher the Anxiety score of the participant, the higher was the ascribed emotional drop down during separation. In contrast to Hypothesis 6, Anxiety did not significantly predict any dependent variable in the Reunion scene. Only one coefficient showed a tendency into the expected direction: anxious individuals tended to initiate more interactions to the spouse ($\beta = .15, p = .089$). This finding, however, is completely in line with the women's results during the pre-separation phase in the study on airport separations (Fraley & Shaver, 1998). In this study, Anxiety as well did not predict overt behavior, but only self-reported distress.

Conflict

For results, see Table 4. During conflict, the protagonists of individuals high in attachment Avoidance showed signs of heightened hostility by expressing less positive (although not more negative) behaviors towards the spouse. In contrast to Hypothesis 7, however, Avoidance did not correlate negatively with the emotional drop down. Hence, Hypothesis 7 was only partially supported. Most prominent, however, are the significant distancing strategies: the protagonists of avoidant individuals had a greater physical distance and initiated fewer interactions to the spouse (Hypothesis 8). Finally, the expected desire for revenge *after* the negative episode was very pronounced in the Next Day scene: avoidant individuals instructed their protagonists to show less positive and more negative behaviors towards the spouse. Furthermore, they ascribed less positive feelings to the protagonist and the ascribed recovery of positive emotions was less pronounced, which fully supports Hypothesis 9.

Table 4: Conflict Condition: Multiple Regression of Game Indices onto Attachment Anxiety and Avoidance

Index	Block 1				Block 2		
	Emotion base line	gender	relationship duration	R ²	Anxiety	Avoidance	ΔR ²
<i>Scene: Conflict</i>							
Distance		.09	.04	.01	.11	.23*	.07*
Spouse- directedness		-.00	-.14	.02	-.01	-.26**	.06*
Positivity		-.17 [†]	-.14	.05*	-.08	-.31***	.10***
Negativity		.00	-.05	.00	.17 [†]	-.04	.03
Positive emotion during conflict ^a	.07	-.08	.01	.01	-.25**	.02	.06*
<i>Scene: Next day</i>							
Distance		.08	.04	.01	.13	.02	.02
Spouse- directedness		-.04	-.01	.00	-.05	-.03	.01
Positivity		-.04	-.13	.02	.02	-.21*	.04 [†]
Negativity		-.11	.21*	.06*	-.06	.42***	.16***
Positive emotion after conflict ^a	.15 [†]	.05	-.07	.03	-.11	-.23*	.07*

Note. Each row refers to standardized regression coefficients of the same hierarchical regression ($n = 131$). Relationship duration and physical distance are transformed (\log resp. $1/x$) to correct for skewness.

^a "Positive emotion" refers to emotions participants ascribed to the protagonist.

[†] $p < .10$. * $p < .05$. ** $p < .01$. *** $p < .001$.

Concerning attachment Anxiety we found support for Hypothesis 10: Anxious individuals ascribed more negative emotions to the protagonist. Hence, cues of possible rejection are perceived as more pronounced by anxious individuals, which replicates Campbell et al.'s (2005) findings. These authors also tested (and confirmed) the hypothesis that signs of *support* are perceived more positively when these occur after the period of conflict. However, in our scenario no explicit resolution of the conflict was shown (the spouse just behaved "normal" again), and no explicit signs of support were signaled. Hence, we would not have expected (and did not find) heightened positive emotions of anxious individuals during the Next Day scene.

Threat

For results, see Table 5.

Table 5: Threat Condition: Multiple Regression of Game Indices onto Attachment Anxiety and Avoidance

Index	Block 1				Block 2		
	Emotion base line	gender	relationship duration	R^2	Anxiety	Avoidance	ΔR^2
<i>Scene: Threat</i>							
Distance		.04	.15 [†]	.02	-.22*	.10	.05*
Spouse- directedness		.16 [†]	-.09	.04 [†]	.03	-.15 [†]	.02
Positivity		-.06	-.14 [†]	.02	.04	-.00	.00
Negativity		.11	.14	.03	-.08	.05	.01
Support seeking		.08	-.01	.01	-.13	-.05	.01
Positive emotion during threat ^a	-.03	.39***	.23**	.22**	-.14	.13 [†]	.03 [†]
<i>Scene: Comfort</i>							
Distance		-.02	.06	.00	-.05	.20*	.04 [†]
Spouse directedness		-.07	-.06	.01	.07	-.04	.00
Positivity		-.20*	-.16*	.06*	.10	-.10	.02
Negativity		.05	-.12	.02	-.07	-.01	.00
Support seeking		-.04	.04	.00	.10	.02	.01
Positive emotion during comfort ^a	.39***	-.05	.00	.18***	-.10	.06	.01

Note. Each row refers to standardized regression coefficients of the same hierarchical regression ($n = 147$). Relationship duration and physical distance are transformed (\log resp. $1/x$) to correct for skewness.

^a"Positive emotion" refers to emotions participants ascribed to the protagonist.

[†] $p < .10$. * $p < .05$. ** $p < .01$. *** $p < .001$.

During the Threat scene, no significant coefficients concerning the behavioral indices could be found for attachment *Avoidance*. One coefficient, however, showed a tendency into the expected direction: the protagonists of avoidant individuals showed less spouse-directedness ($\beta = -.15$, $p = .084$). Hence, Hypothesis 11 could only partially be supported. As expected (Hypothesis 12), avoidant participants neither increased nor decreased the physical distance of their protagonists during the Threat scene. In the Comfort scene, however, they showed a reaction: After the virtual spouse actively approached the protagonist and offered comfort, avoidant participants instructed their protagonists to significantly increase the

physical distance to the spouse (note, however, that although the beta weight was significant, ΔR^2 did not fully reach significance).

Concerning attachment *Anxiety*, we found that anxious individuals' protagonists kept a lower distance to the spouse during the Threat scene, as expected (Hypothesis 13). On the other hand, these individuals did not instruct their protagonists to initiate more interactions, nor did they increase their ratio of positive interactions to the spouse. Hence, while the decreased distance is in line with theoretical predictions, the behavioral null results concerning Anxiety found by Simpson et al. (1992) could be replicated as well.

Using hierarchical regression analyses, we analyzed the interaction between Avoidance and the ascribed emotions during the Threat scene in the prediction of support seeking behavior. Neither the main effects, nor the interaction term reached significance ($ps > .222$).

Discussion

To our knowledge, this is the first study to demonstrate the effect of transference towards an agent in a virtual social environment. Furthermore, while some authors theorized about the application of attachment theory to assess relatedness to virtual characters (Alessi & Huang, 1998), simulated strange situations with autonomous agents (Petters, 2006), or did questionnaire studies about attachment-like qualities to virtual pets (Chesney & Lawson, 2007), this is the first study that observes attachment processes from human adults in virtual environments. We created three different attachment-related scenes in our VSE and could show that the attachment style of participants influenced the way they treated their virtual spouse, and that internal working models indeed are transferred to the relationship with a virtual spouse. We derived specific hypotheses from existing literature and found full support for 7 of our 13 hypotheses, and partial support for 4 hypotheses.

In the separation condition we recreated parts of the classic strange situation procedure: Unexpectedly, the virtual spouse had to leave with an uncertain return. Anxious individuals instructed their protagonist to think more often of the spouse during separation, and ascribed stronger negative emotional reactions to them. As expected, Avoidance was predictive during the reunion episode: When the spouse returned in a lucky turn, protagonists under avoidant individuals' control acted less spouse directed, kept a higher physical distance, and showed less positive interactions with the spouse. Furthermore, these participants ascribed less emotional relieve to the protagonist. These behaviors support the assumption that avoidant individuals were largely unaffected by the reunion. Their behavior showed a striking similarity with the behavior of insecure avoidant children in the strange

situation procedure (Ainsworth et al., 1978). In previous studies that have investigated behavior in naturally occurring couple separations (Fraley & Shaver, 1998; Diamond et al., 2008), the separation always was anticipated by the participants. To our knowledge, this is the first study that investigates behavioral reactions of adults both to an unannounced separation and to the reunion. This highlights the flexibility of the VSE approach to create situations that are difficult to create in vivo.

The conflict condition was created to induce a threat that endangers the attachment bond. Again, anxious individuals ascribed a stronger negative emotional reaction during conflict. However, no behavioral indices were predicted by Anxiety in this condition. As in the separation scene, behavior only was predicted by Avoidance. Avoidant participants expressed their deactivating strategy during conflict by instructing the protagonist to keep a greater distance, with less spouse-directed interactions overall and less positive interactions in particular. When the next day came in Simoland, and the spouse was in good mood again, only avoidant participants' protagonists still showed less positive behaviors. Furthermore, they had a grudge against their spouses, and showed more negative behaviors, as well as more negative emotions. The expected desire for revenge (Mikulincer & Shaver, 2005) clearly could be shown.

The threat condition was created to test whether participants use the virtual spouse as a safe haven in times of an external threat. In this condition, attachment styles only had a minor impact on how participants control their Simo. As expected, anxious participants instructed their protagonists to stay closer to the spouse. When the spouse in turn actively reduced the distance, avoidant participants were in pressure to re-regulate the distance by significantly increasing it. This finding again demonstrates the possibilities of experimentally manipulating the interaction partner's behavior. Apart from physical distance, no other behavioral indices showed correlations to attachment styles. One possible reason is that our specific implementation of a rapid, life-threatening disease was too far away from the everyday experiences of our participants. We also could not replicate the interaction between attachment style and intensity of experienced threat found by Simpson et al. (1992). This might be due to the same reasons. Furthermore, in contrast to this earlier study, our indicator of stress was not observer-rated but a self-reported ascription of emotions.

Attachment theorists assume that the attachment system becomes activated by distressing situations. By systematically varying the type of distress (Is the attachment bond intact, but the figure currently not available? Is the attachment bond itself challenged? Is the attachment figure available, but an external stressor appears?), in our study completely

different patterns of results could be found. In cases where hypotheses only partially could be confirmed, mostly single behavioral indices did not reach significance. However, it has been repeatedly demonstrated that correlations between traits and actual behavior only reach significance if behavioral indicators are aggregated over different behaviors and over a sufficient period of time (Epstein, 1979). Considering that in our study behavioral aggregation only took place over two or three minutes, correlations with both attachment dimensions were rather high. Also, during the separation condition only two behaviors were possible (thinking of the spouse, writing a letter). In future implementations of virtual social environments more behavioral alternatives should be provided to achieve a higher level of aggregation.

Strengths of the Current Study

The current study contributes to the existing literature in two major ways. First, we introduce a new method for the investigation of transference phenomena and behaviors in close relationships, and showed its validity by replicating several results from existing studies. The use of VSEs promises to be a key technique in future investigations of social phenomena, as they open up an unknown flexibility in the experimental manipulation of situations and of the behavior of interaction partners. Within this one 15-minute study, a broader range of attachment-related situations simultaneously could be investigated than in any other single study in the field or the laboratory. Moreover, scenes were created that hardly could have been made up with real persons (an unannounced separation, a couple conflict due to infidelity, a spouse offering comfort under the control of the experimenter).

In the current study we sought to replicate some classic findings. Now that the VSE framework is established, it is relatively easy to construct new scenarios and to explore new realms of attachment-related behavior. Furthermore, technical hurdles are not as high as some readers may assume. Simple two-dimensional characters that are geometric shapes rather than fancy avatars are sufficient to trigger the process of transference. Moreover, we argue that in the study of close relationships these symbolic depictions even work better because visual inconsistencies with the real-life partner prevent a successful immersion into the game (Schönbrodt & Asendorpf, in press). This facilitates the creation and the distribution of VSEs, as both technical and financial requirements are clearly reduced in comparison to more elaborate virtual environments. In contrast to visual realism, we argue that the psychological model of the agents should have a much higher priority. Unfortunately, the interdisciplinary exchange between psychologists and the virtual agents

community that implements psychological models still is rather scarce. Most psychological theories lack the computational and conceptual details that would be necessary to implement them in an autonomous agent, and in some areas like non-verbal behavior or communication a lot of psychological knowledge about specific processes simply is lacking. Many current implementations of autonomous agents therefore rely on *ad hoc* models which are barely based on empirical findings (Krämer, Bente, Eschenburg, & Troitzsch, 2009; Schönbrodt & Asendorpf, 2010). Clearly, future research is needed to further clarify how psychological models can be incorporated into agents and how humans react on them.

Second, this study also contributes to current attachment literature, beyond the replication of existing findings. Fraley and Shaver (2000) have proposed that Anxiety refers to the motivation to monitor and appraise events that are related to attachment-related issues. Avoidance, in contrast, is supposed to regulate behavioral responses to attachment-related issues. Along with that reasoning, our results show that Anxiety nearly exclusively is related to emotional appraisals and not to behavior, a finding that is consistent with several other studies (e.g., Fraley & Shaver, 1998; Simpson et al. 1992). Behavioral reactions, in contrast, nearly exclusively were predicted by Avoidance in the current study. Hence, our study generally supports Fraley and Shaver's (2000) emotional vs. behavioral regulation model.

In addition, our results indicate a further distinction between these two attachment dimensions on a temporal dimension: While the appraisal of the attachment-related threat - the emotional negativation - only is guided by Anxiety, a sort of "secondary appraisal" takes place after the relational threat is over. This emotional recovery only is guided by the Avoidance dimension. This temporal sequence of the attachment process suggests that at the beginning Anxiety imposes a hypervigilance in the detection of potential attachment-related threats, while the subsequent avoidant reaction is the inhibition of emotional expression (Fraley & Shaver, 2000). Probably for the first time, this temporal sequence in emotional appraisals could be empirically confirmed.

Limitations

The community sample of the current study had 84% female participants. Hence, it is questionable whether our results generalize to both genders in the same way. We controlled for gender in our analyses, but separate analyses of both genders were not recommendable due to the low statistical power resulting from the small sample size of men. Furthermore, we acknowledge that our internet sample was less under experimental control than a sample

under laboratory conditions, and that the results based on the self-report measure of attachment style may be biased by social desirability tendencies. Although our reasoning suggests that it is the stable internal working model that influences behavior in Simoland, the correlational nature of our findings does not allow final conclusions about the causal direction.

Future Studies

The proposed VSE framework can be applied to numerous other fields in psychology. For example, social computer games could be used both to instigate specific motives and to provide opportunities to realize them, or to create various kinds of emotion-arousing situations in order to study emotional processes as they unfold over time. Concerning attachment research, specific properties of the internal working models can be investigated. While attachment researchers conceptualized internal working models mostly as generalized knowledge structures, many have emphasized the representations of specific dyadic relationships (e.g., Baldwin, Keelan, Fehr, Enns, & Koh-Rangarajoo, 1996; Cook, 2000; Saribay & Andersen, 2007). They argue that any kind of felt security is grounded in specific relationships and thus linked to distinct significant-other representations. In the current study, we measured a generalized working model with a self-report questionnaire. Future studies could explore whether relationship-specific measures of attachment qualities, or the experimental manipulation of the similarity of the virtual spouse to a past relationship allow new conclusions about the structure of working models.

A lot of current research investigates implicit constructs. In such diverse research fields as implicit personality self-concept (e.g. Asendorpf, Banse, & Mücke, 2002; Egloff & Schmukle, 2002), implicit attitudes (for an overview, see Greenwald, Poehlman, Uhlmann, & Banaji, 2009), implicit motives (McClelland et al., 1989; Spangler, 1992), or implicit working models of attachment (Roisman et al., 2007, Study 3) it has been shown that indirect measures of these implicit constructs often correlate more strongly with spontaneous and uncontrolled behavioral outcomes while direct self-report measures of corresponding explicit constructs more strongly correlate with other self-report measures and with controlled behavioral outcomes. In the case of attachment Anxiety and Avoidance measured by the ECR, it has repeatedly demonstrated that this explicit self-report measure in fact is able to predict behavioral outcomes, both controlled and uncontrolled. Nonetheless, it would be fruitful to compare the predictive validity of direct measures of attachment styles (e.g., the ECR, or the Relationship Questionnaire, Bartholomew & Horowitz, 1991) and

indirect measures of attachment styles (Adult Attachment Interview, Main & Goldwyn, 1998; or the assessment of secure base scripts with the word-prompt-technique, Waters & Waters, 2006) with regard to behavioral outcomes in Simoland.

A possible general objection against the use of virtual environments for the observation of behavior would be the assumption that virtual behavior is completely arbitrary and unrelated to real life. Our results clearly indicate that this is not necessarily the case: Under appropriate conditions, virtual behavior reflects real life behavior. An open question about human behavior in virtual environments, however, surrounds the distinction between defensive projection and projective identification: Do participants express virtual behaviors that they would like to express in reality, either consciously or unconsciously, but are afraid to do for some reasons? Or do participants express the same behaviors they would have shown in a comparable situation in reality? Put in other words: Do participants live out their actual self, an ideal or possible self, or a suppressed self? Possibly, it is a mixture of these and the design of the VSE might influence the exact mix. In any way, future studies will be necessary to shed light on this and other questions to deepen our understanding of human behavior in virtual environments and in general.

References

- Ainsworth, M., Blehar, M. C., Waters, E., & Wall, S. (1978). *Patterns of attachment: A psychological study of the strange situation*. Hillsdale: Lawrence Erlbaum Associates.
- Alessi, N. E., & Huang, M. P. (1998). The potential relevance of attachment theory in assessing relatedness with virtual humans. In G. Riva, B. K. Wiederhold, & E. Molinari (Eds.), *Virtual environments in clinical psychology and neuroscience: Methods and techniques in advanced patient-therapist interaction* (pp. 180-187). Amsterdam, Netherlands: IOS Press.
- Andersen, S. M., & Cole, S. (1990). "Do I know you?": The role of significant others in general social perception. *Journal of Personality and Social Psychology*, *59*, 384-399.
- Andersen, S. M., & Thorpe, J. S. (2009). An IF-THEN theory of personality: Significant others and the relational self. *Journal of Research in Personality*, *43*, 163-170.
- Andersen, S. M., Reznik, I., & Glassman, N. S. (2005). The unconscious relational self. In R. Hassin, J. S. Uleman, & J. A. Bargh (Eds.), *The new unconscious* (pp. 421-481). New York: Oxford University Press.
- Asendorpf, J. B., Banse, R., & Mücke, D. (2002). Double dissociation between implicit and explicit personality self-concept: The case of shy behavior. *Journal of Personality and Social Psychology*, *83*, 380-393.
- Baldwin, M. W., Keelan, J. P. R., Fehr, B., Enns, V., & Koh-Rangarajoo, E. (1996). Social-cognitive conceptualization of attachment working models: Availability and accessibility effects. *Journal of Personality and Social Psychology*, *71*, 94-109.
- Bartholomew, K., & Horowitz, L. M. (1991). Attachment styles among young adults: A test of a four-category model. *Journal of Personality and Social Psychology*, *61*, 226-244.
- Berk, M., & Andersen, S. M. (2000). The impact of past relationships on interpersonal behavior: Behavioral confirmation in the social-cognitive process of transference. *Journal of Personality and Social Psychology*, *79*, 546-562.
- Berk, M., & Andersen, S. M. (2008). The sting of lack of affection: Chronic goal dissatisfaction in transference. *Self and Identity*, *7*, 393-412.
- Blascovich, J., Loomis, J., Beall, A. C., Swinth, K. R., Hoyt, C. L., & Bailenson, J. N. (2002). Immersive virtual environment technology as a methodological tool for social psychology. *Psychological Inquiry*, *13*, 103-124.
- Bowlby, J. (1980). *Attachment and loss*. New York: Basic Books.
- Brumbaugh, C. C., & Fraley, R. C. (2006). Transference and attachment: How do attachment patterns get carried forward from one relationship to the next? *Personality and Social Psychology Bulletin*, *32*, 552-560.
- Brumbaugh, C. C., & Fraley, R. C. (2007). Transference of attachment patterns: How important relationships influence feelings toward novel people. *Personal Relationships*, *14*, 513-530.

- Campbell, L., Simpson, J. A., Boldry, J., & Kashy, D. A. (2005). Perceptions of conflict and support in romantic relationships: The role of attachment anxiety. *Journal of Personality and Social Psychology*, 88, 510-531.
- Chesney, T., & Lawson, S. (2007). The illusion of love: Does a virtual pet provide the same companionship as a real one? *Interaction Studies*, 8, 337-342.
- Cook, W. L. (2000). Understanding attachment security in family context. *Journal of Personality and Social Psychology*, 78, 285-294.
- Dewitte, M., Koster, E. H. W., De Houwer, J., & Buysse, A. (2007). Attentive processing of threat and adult attachment: A dot-probe study. *Behaviour Research and Therapy*, 45, 1307-1317.
- Diamond, L. M., Hicks, A. M., & Otter-Henderson, K. D. (2008). Every time you go away: Changes in affect, behavior, and physiology associated with travel-related separations from romantic partners. *Journal of Personality and Social Psychology*, 95, 385-403.
- Egloff, B., & Schmukle, S. C. (2002). Predictive validity of an implicit association test for assessing anxiety. *Journal of Personality and Social Psychology*, 83, 1441-1455.
- Epstein, S. (1979). The stability of behavior: I. On predicting most of the people much of the time. *Journal of Personality and Social Psychology*, 37, 1097-1126.
- Fraley, R. C. (2007). A connectionist approach to the organization and continuity of working models of attachment. *Journal of Personality*, 75, 1157-1180. doi: 10.1111/j.1467-6494.2007.00471.x
- Fraley, R. C., & Shaver, P. R. (1998). Airport separations: A naturalistic study of adult attachment dynamics in separating couples. *Journal of Personality and Social Psychology*, 75, 1198-1212.
- Fraley, R. C., & Shaver, P. R. (2000). Adult romantic attachment: Theoretical developments, emerging controversies, and unanswered questions. *Review of General Psychology*, 4, 132-154.
- Fraley, R. C., Waller, N. G., & Brennan, K. A. (2000). An item response theory analysis of self-report measures of adult attachment. *Journal of Personality and Social Psychology*, 78, 350-365.
- Frey, A., Blunk, H. A., & Banse, R. (2006). Psi-Land: Paarinteraktionsforschung in einer virtuellen Umgebung [Psi-Land: Investigating interactive behaviour in romantic couples in a virtual environment.]. *Zeitschrift für Sozialpsychologie*, 37, 151-159.
- Furr, R. M. (2009). Personality psychology as a truly behavioral science. *European Journal of Personality*, 23, 369-401.
- Gottman, J. M., & Levenson, R. W. (1992). Marital processes predictive of later dissolution: Behavior, physiology, and health. *Journal of Personality and Social Psychology*, 63, 221-233.
- Greenwald, A. G., Poehlman, T. A., Uhlmann, E., & Banaji, M. R. (2009). Understanding and using the Implicit Association Test: III. Meta-analysis of predictive validity. *Journal of Personality and Social Psychology*, 97, 17-41.
- Hazan, C., Campa, M., & Gur-Yaish, N. (2006). What Is Adult Attachment. In M. Mikulincer & G. S. Goodman (Eds.), *Dynamics of romantic love: Attachment, caregiving, and sex* (pp. 47-70). New York: Guilford Press.
- Heider, F., & Simmel, M. (1944). An experimental study of apparent behavior. *American Journal of Psychology*, 57, 243-259.

- Kenny, D. A., Kashy, D. A., & Cook, W. L. (2006). *Dyadic data analysis*. New York: Guilford.
- Krämer, N., Bente, G., Eschenburg, F., & Troitzsch, H. (2009). Embodied conversational agents. *Social Psychology, 1*, 26-36.
- Mallinckrodt, B., & Chen, E. C. (2004). Attachment and interpersonal impact perceptions of group members: A social relations model analysis of transference. *Psychotherapy Research, 14*, 210-230.
- Main, M., & Goldwyn, R. (1998). *Adult Attachment Rating and Classification Systems (Version 6.0)*. Unpublished manuscript, University of California, Berkeley.
- McCall, C., Blascovich, J., Young, A., & Persky, S. (2009). Proxemic behaviors as predictors of aggression towards Black (but not White) males in an immersive virtual environment. *Social Influence, 4*, 138-154.
- McClelland, D. C., Koestner, R., & Weinberger, J. (1989). How do self-attributed and implicit motives differ? *Psychological Review, 96*, 690-702.
- Meng, X. L., Rosenthal, R., & Rubin, D. B. (1992). Comparing correlated correlation coefficients. *Psychological Bulletin, 111*, 172-175.
- Mikulincer, M. (1998). Adult attachment style and individual differences in functional versus dysfunctional experiences of anger. *Journal of Personality and Social Psychology, 74*, 513-524.
- Mikulincer, M., & Florian, V. (1998). The relationship between adult attachment styles and emotional and cognitive reactions to stressful events. In J. A. Simpson & W. S. Rholes (Eds.), *Attachment theory and close relationships* (pp. 143-165). New York: Guilford Press.
- Mikulincer, M., Gillath, O., & Shaver, P. R. (2002). Activation of the attachment system in adulthood: Threat-related primes increase the accessibility of mental representations of attachment figures. *Journal of Personality and Social Psychology, 83*, 881-895.
- Mikulincer, M., & Shaver, P. R. (2005). Attachment theory and emotions in close relationships: Exploring the attachment-related dynamics of emotional reactions to relational events. *Personal Relationships, 12*, 149-168.
- Mikulincer, M., & Shaver, P. R. (2007). Boosting attachment security to promote mental health, prosocial values, and inter-group tolerance. *Psychological Inquiry, 18*, 139-156.
- Mikulincer, M., Shaver, P. R., & Pereg, D. (2003). Attachment theory and affect regulation: The dynamics, development, and cognitive consequences of attachment-related strategies. *Motivation and Emotion, 27*, 77-102.
- Petters, D. (2006). Implementing a theory of attachment: A simulation of the strange situation with autonomous agents. *Proceedings of the Seventh International Conference on Cognitive Modelling, 7*, 226-231.
- Rholes, W. S., Simpson, J. A., & Oriña, M. M. (1999). Attachment and anger in an anxiety-provoking situation. *Journal of Personality and Social Psychology, 76*, 940-957.
- Roisman, G. I., Holland, A., Fortuna, K., Fraley, R. C., Clausell, E., & Clarke, A. (2007). The Adult Attachment Interview and self-reports of attachment style: An empirical rapprochement. *Journal of Personality and Social Psychology, 92*, 678-697. doi:10.1037/0022-3514.92.4.678

- Sanchez-Vives, M. V., & Slater, M. (2005). From presence to consciousness through virtual reality. *Nature Reviews Neuroscience*, 6, 332-339.
- Saribay, S., & Andersen, S.M. (2007). Are past relationships at the heart of attachment dynamics? What love has to do with it. *Psychological Inquiry*, 18, 183-191.
- Schallberger, U. (2005). *Kurzskala zur Erfassung der Positiven Aktivierung, Negativen Aktivierung und Valenz in Experience Sampling Studien (PANAVA-KS) [Short scales for the assessment of positive affect, negative affect, and valence in experience sampling studies]*. Unpublished manuscript, Department of Psychology, University of Zurich, Switzerland.
- Schönbrodt, F. D., & Asendorpf, J. B. (2010). *The challenge of constructing psychologically believable autonomous agents*. Manuscript submitted for publication.
- Schönbrodt, F. D., & Asendorpf, J. B. (in press). Virtual social environments as a tool for psychological assessment: Dynamics of interaction with a virtual spouse. *Psychological Assessment*.
- Schultheiss, O. C. (2001). An information processing account of implicit motive arousal. In M. L. Maehr & P. Pintrich (Eds.), *Advances in motivation and achievement (Vol. 12: New directions in measures and methods)* (pp. 1-41). Greenwich: JAI Press.
- Schultheiss, O. C., & Pang, J. S. (2007). Measuring implicit motives. In R. W. Robins, R. C. Fraley, & R. F. Krueger (Eds.), *Handbook of research methods in personality psychology* (pp. 322-344). New York: Guilford Press.
- Shaver, P. R., & Mikulincer, M. (2002). Attachment-related psychodynamics. *Attachment & Human Development*, 4, 133-161.
- Shaver, P. R., & Mikulincer, M. (2006). A behavioral system approach to romantic love relationships: Attachment, care-giving, and sex. In R. Sternberg & K. Weis (Eds.), *The new psychology of love* (pp. 35-64). New Haven: Yale University Press.
- Simpson, J. A., & Rholes, W. S. (1998). *Attachment theory and close relationships*. New York: Guilford.
- Simpson, J. A., Rholes, W. S., & Nelligan, J. S. (1992). Support seeking and support giving within couples in an anxiety-provoking situation: The role of attachment styles. *Journal of Personality and Social Psychology*, 62, 434-446.
- Simpson, J. A., Rholes, W. S., Oriña, M. M., & Grich, J. (2002). Working models of attachment, support giving, and support seeking in a stressful situation. *Personality and Social Psychology Bulletin*, 28, 598-608.
- Simpson, J. A., Rholes, W. S., & Phillips, D. (1996). Conflict in close relationships: An attachment perspective. *Journal of Personality and Social Psychology*, 71, 899-914. doi:10.1037/0022-3514.71.5.899
- Spangler, W. (1992). Validity of questionnaire and TAT measures of need for achievement: Two meta-analyses. *Psychological Bulletin*, 112, 140-154.
- Steiger, J. H. (1980). Tests for comparing elements of a correlation matrix. *Psychological Bulletin*, 87, 245-251.
- Vormbrock, J. (1993). Attachment theory as applied to wartime and job-related marital separation. *Psychological Bulletin*, 114, 122-144.

- Waters, H. S., & Waters, E. (2006). The attachment working models concept: Among other things, we build script-like representations of secure base experiences. *Attachment and Human Development*, 8, 185-197.
- Wilcox, R. R. (2005). *Introduction to robust estimation and hypothesis testing* (2nd ed.). San Diego: Academic Press.
- Yee, N., Bailenson, J., & Rickertsen, K. (2007). A meta-analysis of the impact of the inclusion and realism of human-like faces on user experiences in interfaces. *Proceedings of the SIGCHI conference on Human factors in computing systems*, 1-10.

Curriculum Vitæ Felix Schönbrodt (Stand: 26.8.2010)

Persönliche Angaben:

Felix Schönbrodt
 Oberländer Str. 63a
 86163 Augsburg
 Geburtsdatum: 13.07.1980, Starnberg
 Email: felix.schoenbrodt@web.de

Akademische Ausbildung:

1990 - 1999	Rudolf-Diesel-Gymnasium, Augsburg (Abiturnote: 1,5).
1999 - 2000	Zivildienst im Behindertenwohnheim "Ulrichsheim", Augsburg.
2000 - 2006	Studium Psychologie (Diplom) an der Universität des Saarlandes (Diplomnote: 1,1) Diplomarbeit: "Das Evolutionäre Motivprofil - Entwicklung eines Motivfragebogens zum Zürcher Modell sozialer Motivation und seine Validierung an der PRF-D, dem MMG sowie biographischen Angaben".
2007 - 2010	Promotion bei Prof. Dr. Jens B. Asendorpf (Humboldt-Universität zu Berlin). Thema: "Transference of relationship qualities to a virtual world: Regulation of behavior to a virtual spouse".

Praktika, Auslandsaufenthalte und Stipendien:

03/2003 - 06/2003	Wissenschaftliches Praktikum am Max-Planck-Institut "Recht der Gemeinschaftsgüter" in Bonn.
08/2004 - 03/2005	Praktikum und anschließende Tätigkeit als freier Mitarbeiter bei der SIPA Unternehmer Beratung GmbH (Saarbrücken/ Chemnitz).
08/2006	Stipendium der Volkswagen-Stiftung für die Sommerschule "Evolutionäre Anthropologie" am Hanse-Wissenschaftskolleg in Delmenhorst.
07/2007	Stipendium für die Sommerschule der International Society for Human Ethology (ISHE) am MPI Seewiesen.
2007-2010	Promotionsstipendium bei der Studienstiftung des deutschen Volkes.
08/2009 - 11/2009	Stipendium für Forschungsaufenthalt an der Stony Brook University (New York) bei Prof. Markus Maier.
05/2010 - 08/2010	Stipendium vom "Google Summer of Code" zur Erstellung einer statistischen Software ("TripleR: A package for social relations analyses").

Sonstiges:

1995-1997	Ehrenamtliche Mitarbeit in der Konfirmandenarbeit (Auferstehungsgemeinde Hochzoll-Süd, Augsburg).
2002-2005	Gewählter Fachschaftsrat der Fachrichtung Psychologie.
2002-2006	Studentisches Mitglied im Prüfungsausschuss der Fachrichtung Psychologie.
2002 - 2005	Initiierung, Mitorganisation und Durchführung von drei Evaluationen der Lehrqualität an der Fachrichtung Psychologie.
2003-2005	Initiierung und Leitung des Projekts "Praxisseminare für Studierende" im Rahmen des Anreizprogramms für innovative Lehre an der Universität des Saarlandes.
2005-2006	Gründung und Aufbau der psychologischen Beratungsfirma Yavis (www.yavis.de); 09/2006 Austritt als Gesellschafter wegen Promotion.
Fremdsprachen	Englisch (fließend)
EDV-Kenntnisse	Ausgezeichnete Kenntnisse in Office-Anwendungen (Word, Excel, Powerpoint), Programmiersprachen (PHP, HTML, AS3), Statistiksoftware (SPSS, R).
Hobbys & soziale Aktivitäten	- Aikido - Tanzen (Standard & Latein im Tanzverein, argentinischer Tango) - Segeln - Klavier spielen (Jazz, Tango) - Kochen

Schriftenverzeichnis von Felix Schönbrodt (Stand: 26.8.2010)

Publikationen in begutachteten Zeitschriften

- Schönbrodt, F. D., & Asendorpf, J. B. (2010b). *Transference of adult attachment dynamics to a virtual spouse*. Manuscript submitted for publication.
- Schönbrodt, F. D., & Asendorpf, J. B. (2010a). *The challenge of constructing psychologically believable autonomous agents*. Manuscript submitted for publication.
- Schönbrodt, F. D., & Asendorpf, J. B. (in press). Virtual social environments as a tool for psychological assessment: Dynamics of interaction with a virtual spouse. *Psychological Assessment*.
- Petters, D., Waters, E., & Schönbrodt, F. D. (2010). Strange carers: Robots as attachment figures and aids to parenting. *Interaction Studies: Social Behaviour and Communication in Biological and Artificial Systems*, 11, 246-252.
- Schönbrodt, F. D., Unkelbach, S. R., Spinath, F. M. (2009). Broad motives in short scales: A questionnaire for the Zurich model of social motivation. *European Journal of Psychological Assessment*, 25, 141-149.
- Schönbrodt, F. D., & Schwab, F. (2008). Transportation. In N. C. Krämer, S. Schwan, D. Unz, & M. Suckfüll (Eds.), *Medienpsychologie. Schlüsselbegriffe und Konzepte* (pp. 213-217). Stuttgart: Kohlhammer.
- Schönbrodt, F. D. (2007). Interview mit Prof. Dr. Karl Grammer. *Zeitschrift für Medienpsychologie*, 19, 160-161.

Sonstige Publikationen, Software, Workshops

- Schmukle, S. C., Schönbrodt, F. D., & Back, M. D. (2010). *TripleR: A package for round robin analyses using R (version 0.4.3)*. Retrieved from <http://www.persoc.net>.
- Schönbrodt, F. D. (2009, April). *Einführung in R (Workshop zu Round-Robin-Analysen sozialer Interaktion)*. Humboldt-Universität zu Berlin.
- Schönbrodt, F. D. (2006). *Das Evolutionäre Motivprofil. Entwicklung eines Motivfragebogens zum 'Zürcher Modell sozialer Motivation' und seine Validierung an der PRF-D, dem MMG sowie biographischen Angaben* (Diplomarbeit). Online in Internet: <http://psydok.sulb.uni-saarland.de/volltexte/2008/1578/>

Vorträge

- Schönbrodt, F. D. & Hagemeyer, B. (2010, Juli). *Ein Kuli hat kein Backspace - werden spontane Motivausdrücke in Computer-PSEs wieder gelöscht?* Vortrag auf dem 30. MPK (Motivationspsychologisches Kolloquium), Mannheim.
- Schönbrodt, F. D. & Zehetleitner, M. (2010, März). *Ein Lächeln schenkt nicht immer Freude. Eine empirische Untersuchung von 7 Lächelvarianten*. Vortrag auf der 52. TeaP (Tagung experimentell arbeitender Psychologen), Saarbrücken.
- Schönbrodt, F. D. (2009, Oktober). *Assessing interaction dynamics in virtual environments*. Eingeladener Vortrag an der Ryerson University, Toronto.

- Schönbrodt, F. D. (2009, Oktober). *Intimacy, autonomy, and ego-boundaries: The dance of distance*. Vortrag an der Stony Brook University, New York.
- Denissen, J., Schönbrodt, F. D., Selfhout, M. (2009, September). *Je bekannter, desto fremder: Eine aufschlussreiche Anomalie bei der Intelligenzeinschätzung*. Vortrag auf der 10. Fachgruppenkonferenz der DPPD, Landau.
- Schönbrodt, F. D. (2009, Juli). *Die Psychologie der Ich-Grenze*. Vortrag im Kolloquium der Sozialpsychologie, Department Psychologie, Ludwig-Maximilians-Universität München.
- Schönbrodt, F. D. (2009, Februar). *Robuste Statistiken und logistische Multilevel-Analysen von virtuellem Interaktionsverhalten*. Vortrag im Kolloquium Advances in Personality and Relationship Science, Humboldt-Universität zu Berlin.
- Schönbrodt, F. D. (2009, Januar). *Partnerschaft und Persönlichkeitsentwicklung*. Vortrag auf der 2. Konferenz von PERSOC, Berlin.
- Schönbrodt, F. D. (2008, September). *Lieben Sie Ihren virtuellen Partner? Die Messung des impliziten Intimitätsmotivs durch ein Computerspiel*. Vortrag auf dem 28. MPK (Motivationspsychologisches Kolloquium), Trier.
- Schönbrodt, F. D. (2008, Juli). *How do you treat your virtual partner? Assessment of implicit motives with a computer game*. Vortrag auf dem XXIX International Congress of Psychology, Berlin.
- Schönbrodt, F. D. (2007, September). *TIMVE - Ein impliziter Motivtest in virtuellen Welten*. Vortrag auf dem 28. MPK (Motivationspsychologisches Kolloquium), Siegen.
- Schönbrodt, F. D. (2007, Juli). *The 'virtual field' - a new paradigm for behavioral observations?* Vortrag auf der Sommerschule der ISHE (International Society for Human Ethology), MPI Seewiesen.
- Schönbrodt, F. D. (2006, August). *Das Fundament der Motivation - Die evolutionären Grundlagen menschlicher Motive*. Vortrag auf der Sommerschule "Evolutionäre Anthropologie" am Hanse-Wissenschaftskolleg Delmenhorst.

Poster

- Schönbrodt, F. D. (2007, September). *Intimität und Autonomie - Ein impliziter Motivtest in virtuellen Welten*. Poster auf der Fachgruppentagung Differentielle Psychologie, Persönlichkeitspsychologie und Psychologische Diagnostik (DPPD), Wien.
- Schönbrodt, F. D. (2007, Juli). *Do you trust your 'virtual partner'? Cooperation towards a self-modelled avatar of your partner*. Poster auf der 13. Konferenz der ISSID (International Society for the Study of Individual Differences), Gießen.
- Schönbrodt, F. D., Unkelbach, S. R. (2007, März). *Das Evolutionäre Motivprofil (EMP-Z)*. Poster auf der 8. MVE-Tagung (Menschliches Verhalten in evolutionärer Perspektive), Landau.
- Schönbrodt, F. D., Unkelbach, S. R. (2006, März). *Ein evolutionäres Persönlichkeitsmodell - die "Tiefenstruktur" der Persönlichkeit?* Poster auf der 7. MVE-Tagung (Menschliches Verhalten in evolutionärer Perspektive), Köln.